



# SIDE-POWER Thruster Systems

# SH

- 1000/513

- 1400/610

## Installation manual



### SLEIPNER MOTOR AS

P.O. Box 519

N-1612 Fredrikstad

Norway

[www.side-power.com](http://www.side-power.com)

Document id: 5939

Revision: 7

Date: 2020



Made in Norway

© Sleipner Motor AS 2020

**Installation instructions**

Bow Installation Considerations and Precautions .....	3
Thruster Measurements .....	4
Thruster Specifications .....	5
Technical Specifications .....	5
Positioning of the tunnel/ thruster .....	6
Tunnel Length.....	7
Tunnel Installation in Sailboats .....	8
Water Deflection .....	9
Tunnel ends .....	10
Tunnel Installation .....	11 - 12
Stern Tunnel Installation .....	13

**Thruster installation**

Hydraulic Thruster Installation Considerations and Precautions..	14
.....	14
Technical Specifications .....	15
Technical Requirements / Hydraulic hose connections to motor..	16
.....	16
Crossover Valve .....	17
Gear Leg & Motor Bracket Installation .....	18
Propeller Installation .....	19
Motor Installation .....	20
Oil Tank Installation .....	21
S-link Planning & Precautions .....	22
Control Panel Installation.....	23
Checklist for Hydraulic Thrusters.....	24

<b>Spare Parts.....</b>	<b>25</b>
-------------------------	-----------

<b>Warranty statement .....</b>	<b>25</b>
---------------------------------	-----------

**Products**

SM905333 | SH1400/610-BA110 - SH1400 Tunnel thruster, BA110  
 SM908033 | SH1400/610-BA150 - SH1400 Tunnel thruster, BA150  
 SM905334 | SH1400/610-BA180 - SH1400 Tunnel thruster, BA180  
 [Archived] SH1400/610-BA080 - SH1400 Tunnel thruster, BA80  
 SM908032 | SH1400/610-BA125 - SH1400 Tunnel thruster, BA125  
 SM102941 | SH1400/610-BA160 - SH1400 Tunnel thruster, BA160  
 SM908034 | SH1400/610-BA80 - SH1400 Tunnel thruster, BA80  
 SM102972 | SH1000/513-BA110D13 - SH1000 Tunnel thruster, BA110  
 SM103522 | SH1000/513-BA90 - SH1000 Tunnel thruster, BA90  
 SM114788 | SH1000/513-BA80 - SH1000 Tunnel thruster, BA80  
 SM908030 | SH1000/513-BA75 - SH1000 Tunnel thruster, BA75  
 SM905330 | SH1000/513-BA60 - SH1000 Tunnel thruster, BA60  
 SM908031 | SH1000/513-G70 - SH1000 Tunnel thruster, G70  
 SM908029 | SH1000/513-BA45 - SH1000 Tunnel thruster, Ø513mm  
 SM102899 | SH1000/513-BA125 - SH1000 Tunnel thruster, BA125  
 SM905331 | SH1000/513-G75 - SH1000 Tunnel thruster, G75  
 [Archived] SH1000/513-BA110 - \* BRUK SH1000/513-BA110D13  
 SM905332 | SH1000/513-G80 - SH1000 Tunnel thruster, G80

**DECLARATION OF CONFORMITY**

MC\_0020



Sleipner Motor AS  
 P.O. Box 519, Arne Svendsensgt. 6-8  
 N-1612 Fredrikstad, Norway

Declare that this product with accompanying standard control systems complies with the essential health and safety requirements according to:

DIRECTIVE 2013/53/EU  
 DIRECTIVE 2014/30/EU  
 DIRECTIVE 2014/35/EU

### It is the installers responsibility

When installing Side-Power equipment to follow the outlined regulations/ classification rules (electrical/ mechanical) according to international or special national regulations. Instructions in this guide cannot be guaranteed to comply with global electric/ mechanic regulations/ classification rules.

To follow all health and safety laws in accordance with their local outlined regulations/ classification rules.

Before installation, it is important that the installer reads this guide to ensure necessary acquaintance with this product.

The recommendations made in this manual are guidelines ONLY, and Sleipner Motor AS (Side-Power) strongly recommend that before installation, advice is obtained from a naval architect familiar with the particular vessel and regulations/ classifications.

This manual is intended to support educated/ experienced staff and is therefore not sufficient in all details for professional installation. *(NB: These instructions are only general instruction. If you are not skilled to do this work, please contact professional installers for assistance.)*

All electrical work must be done by a licensed professional.

**Faulty installation of the tunnel, thruster or panel will render all warranty given by Sleipner Motor AS void.**

MC\_0038

EN

## Planning Considerations and Precautions

MC\_0113

- Do not install the thruster in a position where you need to cut a stiffener/ stringer/ support for the hull integrity without checking with the boat builder this can be done safely.
- The motor, its components, contacts/ plugs or other joints in the control cables must be mounted so they will remain dry at all times.
- We advise painting the gear house and propellers with antifouling. **(NB: Do not paint the anodes, sealings, rubber fittings or propeller shafts)**
- Do not finish the inside of the tunnel with a layer of gelcoat/ topcoat or similar. There is only room for a thin coat of primer and two layers of anti-fouling between the tunnel and the propellers.
- Keep installation within advised measurements. The entire surface is hard coated seawater resistant aluminium. Do not damage or penetrate the coat.
- Install the oil tank higher than the pumps to ensure enough gravity feed and pressure for feed ports. **(NB: The height of oil levels in the hydraulic tank should be higher than the connected hydraulic pumps.)**
- Find a suitable location for the hydraulic tank installation for future maintenance accessibility. There must be enough space around the oil tank to change filters, fill oil and inspect gauges and indicators.

EN

## Hydraulic Thruster Installation Considerations and Precautions

MC\_0009

**Before installation, The installer must read this guide to ensure necessary acquaintance with this product.**

- If the height of the room you are installing the Side-Power is limited, it can be installed horizontally or at any angle in-between.
- The motor must be handled with care. Do not rest on the driveshaft.

**If an original Side-Power hydraulic system is NOT installed, please ensure the following:**

- Install an oil filter to keep the oil clean.
- Fit an oil cooler or use an oil tank to ensure the maximum oil temperature is 43 - 50 degrees Celcius.
- Hydraulic thrusters are supplied with hydraulic motors only.
- The installed hydraulic system is the responsibility of the fitter/ installer and must be within the limitations outlined in this manual to ensure no damage is caused to the thruster.
- The hydraulic valve must have flow and pressure limits that are either set within or can be adjusted to the limits of the thrusters capability.
- We strongly advise that a shock valve is fitted and set to 10% - 15% above the chosen maximum pressure set in the valve. This will prevent the system from being damaged if the propellers are blocked for any reason.
- It is required that a device is installed to ensure that the drive direction cannot be suddenly changed, as this can severely damage the gear house. **(NB: By adding an electronic time-lapse/delay safety on the electric control system or by using a valve that has this type of protection built in will prevent this issue. \*The required time delay is 1 second.)**

### IMPORTANT

**If installing S-link products DO NOT connect any other control equipment to the S-link controlled products except Side-Power original S-link products or via a Side-Power supplied interface product made for interfacing with other controls. Any attempt to directly control or at all connect into the S-link control system without the designated and approved interface will render all warranties and responsibilities for the complete line of Side-Power products connected void and null. If you are interfacing by agreement with Sleipner and through a designated Side-Power supplied interface, you are still required to also install at least one original Side-Power control panel to enable efficient troubleshooting if necessary.**

MC\_0265

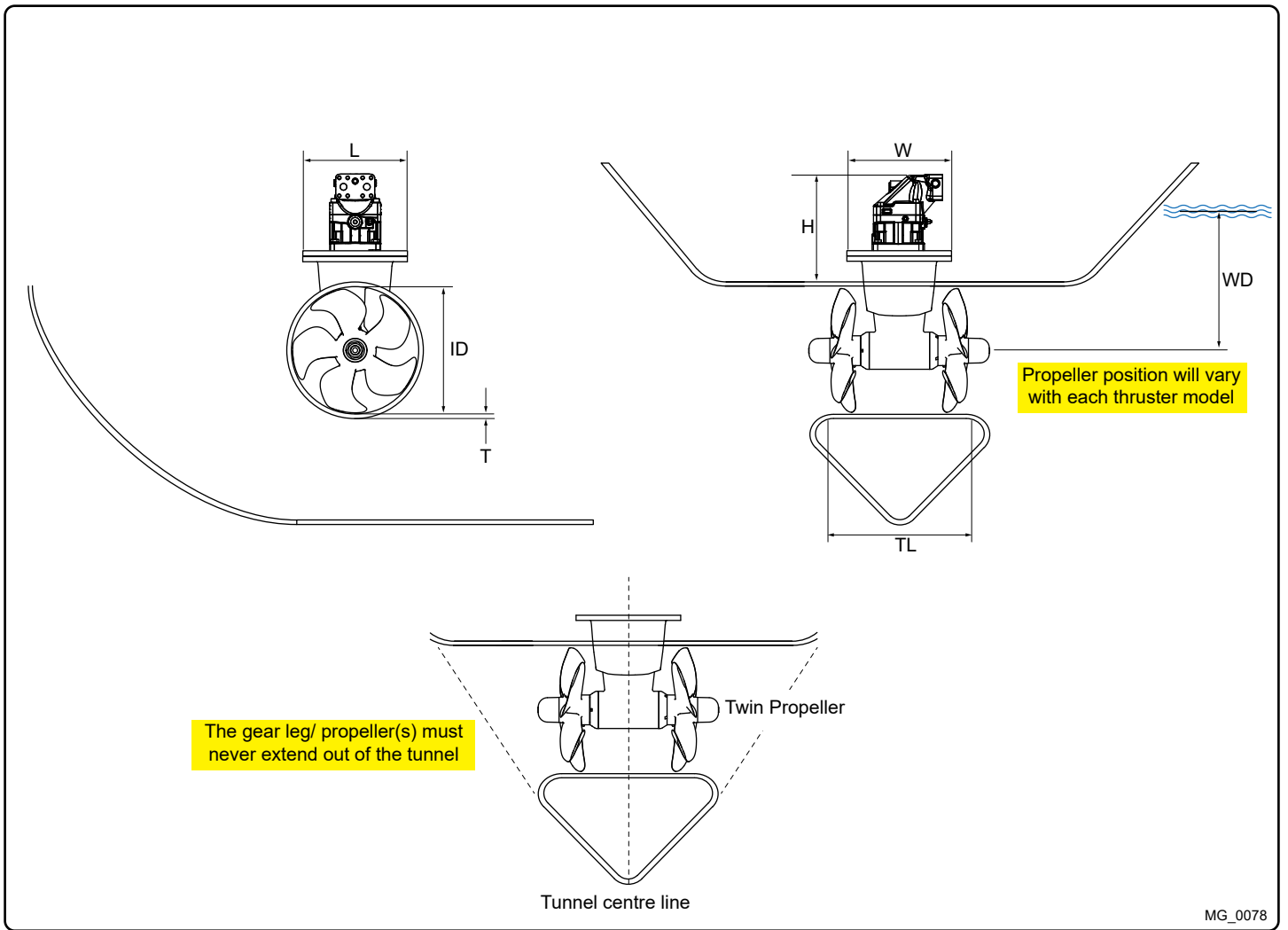

MG\_0078



## Thruster Measurements

MC\_0189

Measurement code	Measurement description	*1000		*1400	
		mm	inch	mm	inch
ID	Internal tunnel diameter	513	7,28	610	24,02
H	Motor Height	486	19,13	500	19,69
W	Width	398	15,67	398	15,67
L	Length	398	15,67	398	15,67
WD	Water Depth	750	29,53	900	35,43
TL	Minimum tunnel length	750	29,53	750	29,53
TL (recommended)	Recommended tunnel length	1000	39,37	1000	39,37
T (min)	Minimum tunnel wall thickness	16	0,24	18	0,71
T (max)	Maximum tunnel wall thickness				

description	* 1000	* 1400
light duty thrust up to (kg * lbs)		
Heavy duty thrust up to (kg * lbs)	1000kg * 2205lbs	1400kg * 3085lbs
Typical Boat Size (m * ft)	30m - 45m * 100ft - 150ft	40m - 55m * 130ft - 175ft
Propulsion System	Twin Counter Rotating	Twin Counter Rotating
Power (kw * Hp)	59.8kw * 80.2hp	80.1kw * 107.4hp
Weight (kg * lbs)	168 - 182 kg * 370 - 401 lbs	211 kg * 465.17 lbs
Lubrication	Gravity Feed/ On water change	Gravity Feed/ On water change

- Motor:** Hydraulic type (specifications above).
- Gearhouse:** Seawater resistant bronze. Ballbearing at propeller shaft and a combination of ball bearing and slide bearing at driveshaft.
- Gears:** Hardened precision gears.
- Lubrication:** Oil bath from tank (gear oil GL-5).
- Bearings:** Angular contact ball bearing at propellershaft and combination of ball bearing and needle bearing at driveshaft.
- Motor bracket:** Seawater resistant aluminium, galvanically insulated from the motor.
- Tunnel:** Cross spun with rowing G.R.P tunnel  
Steel & aluminium tunnels available at request.
- Propeller:** Symmetrical bronze 5-blade skew "Q-prop" propeller.
- Safety:** Flexible coupling between hydraulic-motor and driveshaft protects gearsystem if propeller jams.

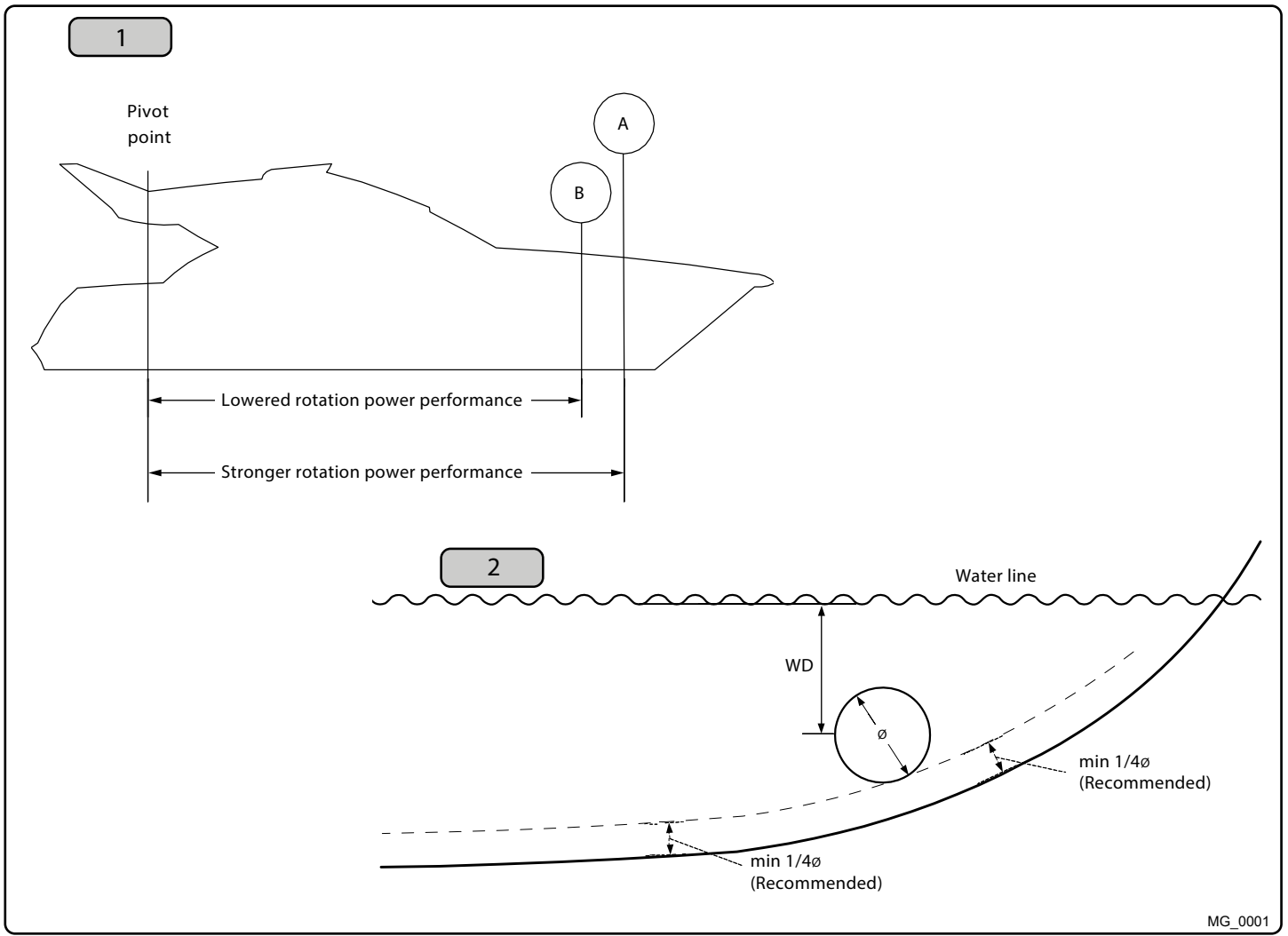

MG\_0001

**EN** **Positioning of the tunnel / thruster** **MC\_0003**

**Aim to install the thruster as far forward as possible (1)**

Due to the leverage effect around the boats' pivot point. The distance difference from the boat pivots' point to the thruster will determine the amount of real rotation power for the boat.

**Aim to install the thruster as deep as possible under the waterline (2)**

Deeper installations prevent air from being sucked into the tunnel from the surface, resulting in reduced thrust performance and increase noise levels during operation. Deeper installations increase water pressure for maximum efficiency from the thruster.

The centre of the tunnel should be a minimum of 1 x the tunnel diameter below the waterline. The installer must make evaluations based on thruster performance, boat type and operating conditions. As a general recommendation, the position of the tunnel should not be a minimum of 1/4 of the diameter of the tunnel from the boat keel. **(NB: This can be overlooked depending on the installation methods defined in this manual.)**

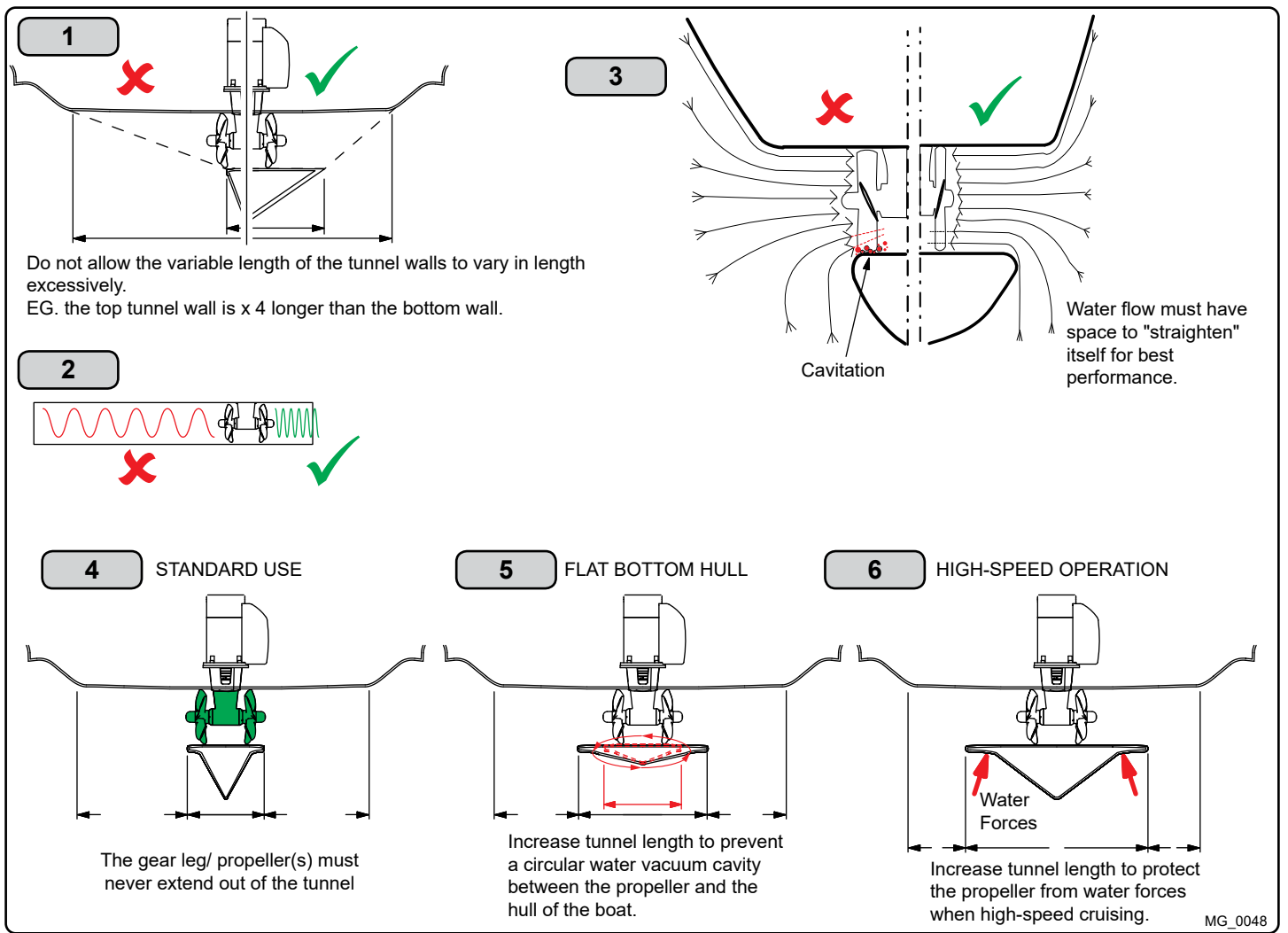

**EN** **Tunnel Length** **MC\_0003**

**Optimal tunnel length**

Achieving the correct tunnel length depends on many factors from the hull type, operation and environmental conditions. Tunnels should avoid being longer than 4 x the tunnel diameter as this will reduce thruster performance. **(NB: Installing long length tunnels can flex/bend over time and may require additional support. Consult with a naval architect.)**

1. Do not allow the variable length of the tunnel walls to vary in length excessively.  
EG. the top tunnel wall is x 4 longer than the bottom wall.
2. If the tunnel is too long, the friction inside will reduce the water speed and thereby the thrust.
3. If the tunnel is too short (typically only in the bottom section of the tunnel) cavitation problems can occur as water flow will not be able to "straighten" itself before reaching the propeller. This cavitation will reduce performance and increase noise during operation.

**Thruster within the tunnel**

It is important the propellers and the lower unit/ gear leg must be entirely inside the thruster tunnel. Propellers that protrude from the tunnel will not perform as intended.

4. **Standard Use**  
Tunnel length must be long enough to ensure the propellers are not extruding the tunnel.
5. **Flat Bottom Hull**  
Tunnel lengths must be longer than the standard measurement outlined within the manual to ensure a circular vacuum is not created between the thruster and the bottom of the boat.
6. **High-Speed Boats**  
Tunnel lengths must be increased to protect the propeller from damage when crashing against the water surface during high-speed cruising. **(NB: This can include the length of a spoiler)**

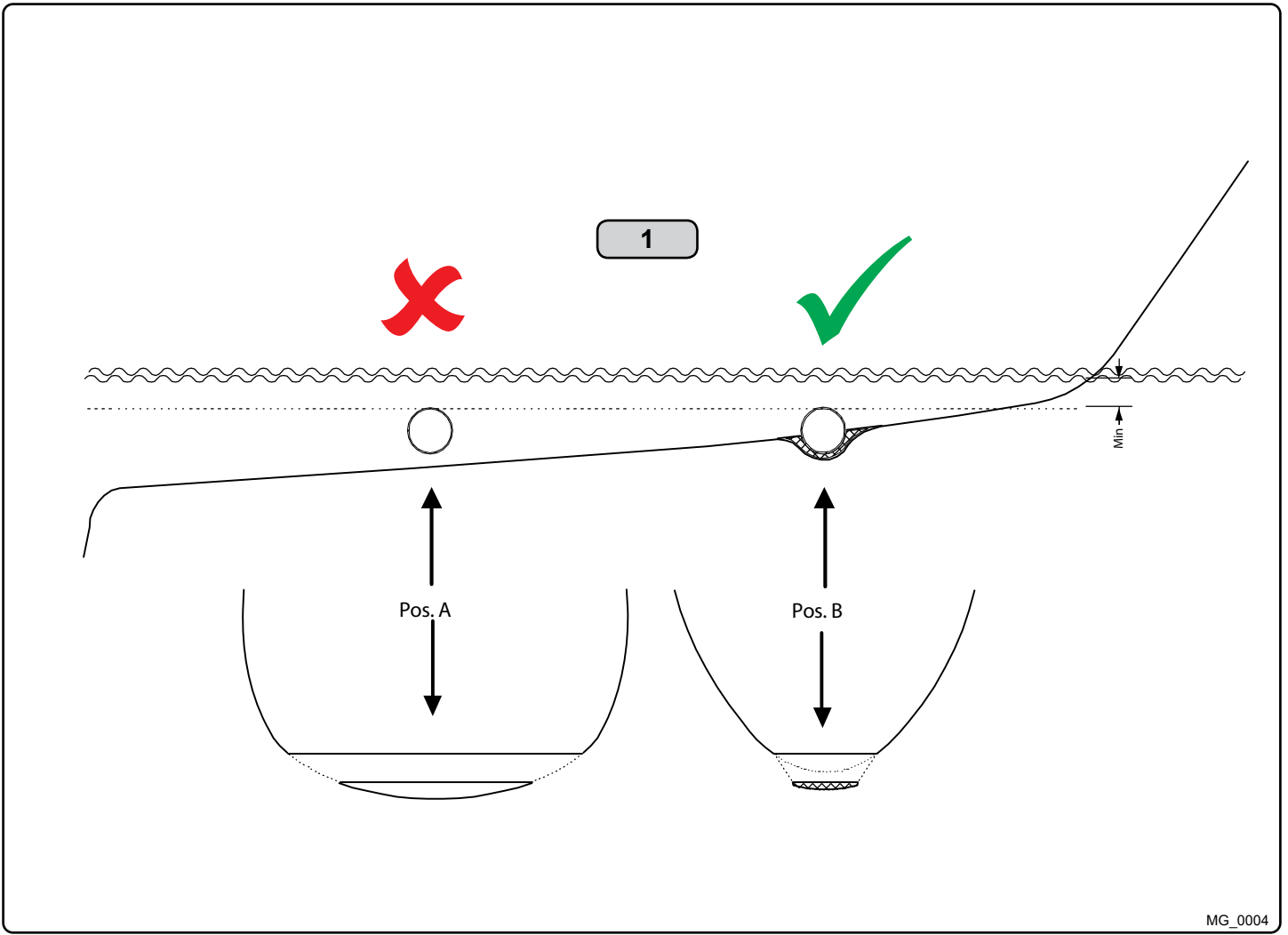

**EN** **Tunnel installation in sailboats** **MC\_0003**

Some sailboats have a flat bottom and shallow draft in the bow section. This can make installing the thruster as far forward from the boats main pivot point difficult. (Fig. 1).

However, it is possible to install a tunnel thruster in most sailboats, even when the hull does not directly support the fitting of a tunnel.

Instead fit the tunnel halfway into the underneath section of the existing hull. Strengthen it with a deflector/ spoiler directing the water flow around the tunnel. This will allow installation of the thruster in the proper position on the boat, maintaining the reliability and space advantages of the tunnel thruster.

This installation is being used by some of the world's largest sailboat builders and has proven to give little to no speed loss during normal cruising. This can also be an installation method for flat bottomed barges to avoid extremely long tunnels and large oval tunnel openings in the hull.



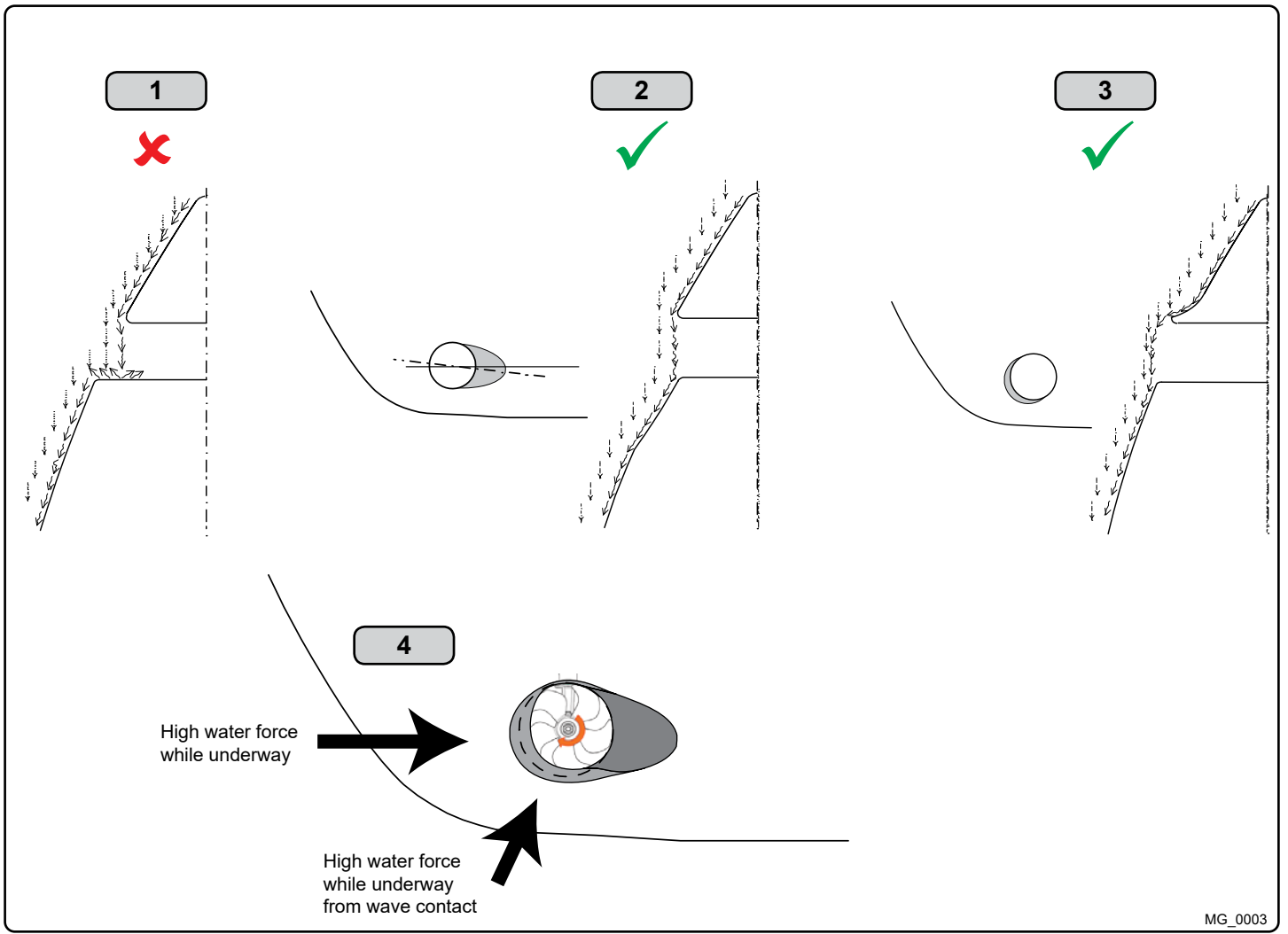

MG\_0003

EN

## Water Deflection

MC\_0003

1. A possible problem in sailboats or fast powerboats is that a non-rounded surface can generate drag from the back face of the tunnel, as it creates a "flat" area facing the flow of water (1).

This problem can be solved in two different ways, depending on what is possible or easier to perform.

2. The best solution which generally reduces the most drag is to make a recess in the hull at the back of the tunnel. As the back face is removed water can flow freely past the tunnel entry. The depth and shape of this recess will depend on the boat and the angle facing up/ down aft of the tunnel insert. Normally it is angled slightly down because of the water flow on this area (2).
3. Making a deflector/ spoiler in front and underneath the tunnel can also reduce damage to the thruster and drag. The deflector/ spoiler will push the water flow out from the hull so water can pass by the back face of the tunnel. The shape and size of this deflector/ spoiler will depend on the hull shape. The easiest way of making the deflector/ spoiler is to retain a part of the lower forward area of the tunnel while installing the tube. Use this area as support to mould a soft curve/spoiler shape from the hull. (3).
4. The thruster propeller can spin (passively) producing noise while sailing or cruising as water is forced through the tunnel. Waterflow directed through the tunnel at high speeds, during turning or as the boat bumps waves while underway can also damage the thruster (4).

**(NB: As a rule, you should not see the back face of the tunnel when standing directly in front of the boat looking aft.)**

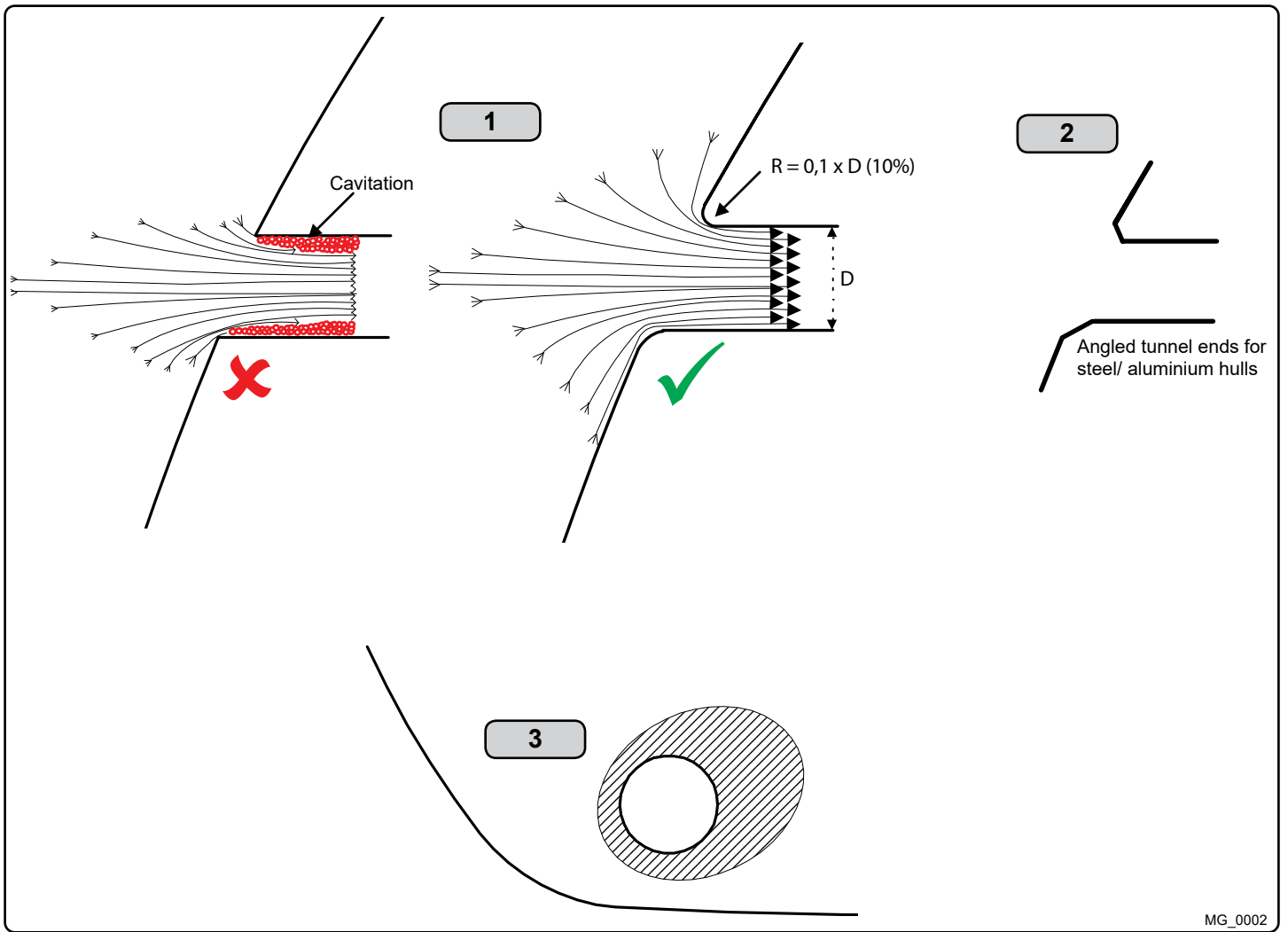

**Rounded tunnel ends will maximise thrust and minimise noise and cavitation.**

For best performance round the tunnel connection to the hull-side as much as possible. The minimum rounding has a radius of 10% of the diameter of the tunnel.

Significant advantages of a rounded tunnel over a sharp tunnel to hull connections are:

1. A rounded tunnel end will prevent the creation of turbulence/ cavitation created from a sharp tunnel end when water passes by the tunnel.
  - The turbulence/ cavitation will block the outer area of the tunnel and thereby reduces the effective tunnel diameter and thrust.
  - Turbulence/ cavitation on the propeller will lessen the thrusters performance and create excess noise.
2. For steel/ aluminium hulls angled tunnel ends also offer similar performance as a rounded connection.
3. A rounded tunnel end makes the thruster draw water from along the hull-side, creating a vacuum that will suck the boat sideways and thereby give additional thrust.
  - With a sharp tunnel end, the thruster will be unable to take water from along the hull-side, and you will not gain the desired vacuum and additional thrust. This "free" extra thrust in optimal installations be 30 - 40% of the total thrust.

**(NB: A Side-power thruster propeller does not produce cavitation at working speed. Therefore, any cavitation and cavitation noise in the tunnel will be caused during improper tunnel installation.)**

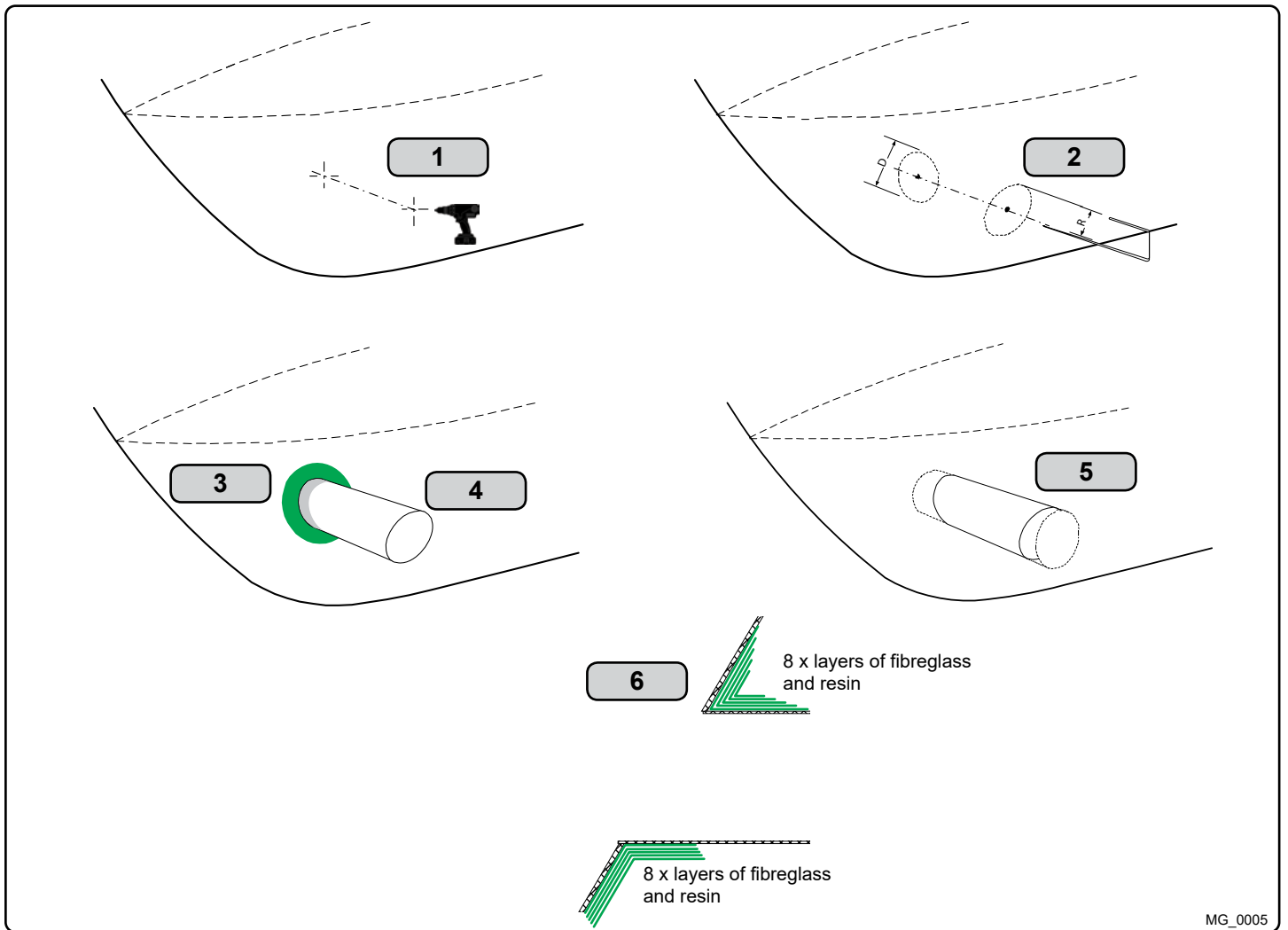

MG\_0005

EN

## Tunnel installation

MC\_0003

### IMPORTANT

We recommend that a professional does the fibreglass, steel or aluminium fitting of the tunnel. These instructions are only general instructions and do not explain in any way the details of fibreglass work. Problems caused by faulty installation of the tunnel, are the installers full responsibility.

1. Find the position in the boat considering the information earlier in this manual and the applicable measurements for the thruster model you are installing. Mark the centre of the tunnel on both sides of the hull. Drill a hole horizontally at these marks.
2. Mark the circle for the tunnel opening (outside diameter of the tunnel) and cut the hole.
3. Grind off the the gel coat to the "real fibreglass" area 12cm around the hole on both inside and outside the hull to cast the tunnel to the hull (**Fig. 3**).
4. Insert the tunnel and mark its shape to fit the hull. **(NB: if you are installing with a deflector/ spoiler, leave a part of the tunnel in the front and underside of the tunnel that will cover the back face.)**
5. Cut the tunnel ends to the desired shape and lightly sand its surface. Clean the area with acetone or similar where you are going to apply fibreglass. **(NB: Do not cast or add fibreglass to the area were the thruster will be placed.)**
6. Cast the tunnel to the inside of the hull, use at least eight layers of 300g fibreglass and resin, preferably alternating mat and rowing types of fibreglass. To round the tunnel ends to a 10% radius make further layers inside to preserve the desired hull thickness.

**(NB: Ensure gaps between the tunnel and the hull are completely filled with resin/ fibreglass. In areas where you can not access to make layers of resin/ fibreglass, a resin/ fibreglass mixture must be used in that area.)**

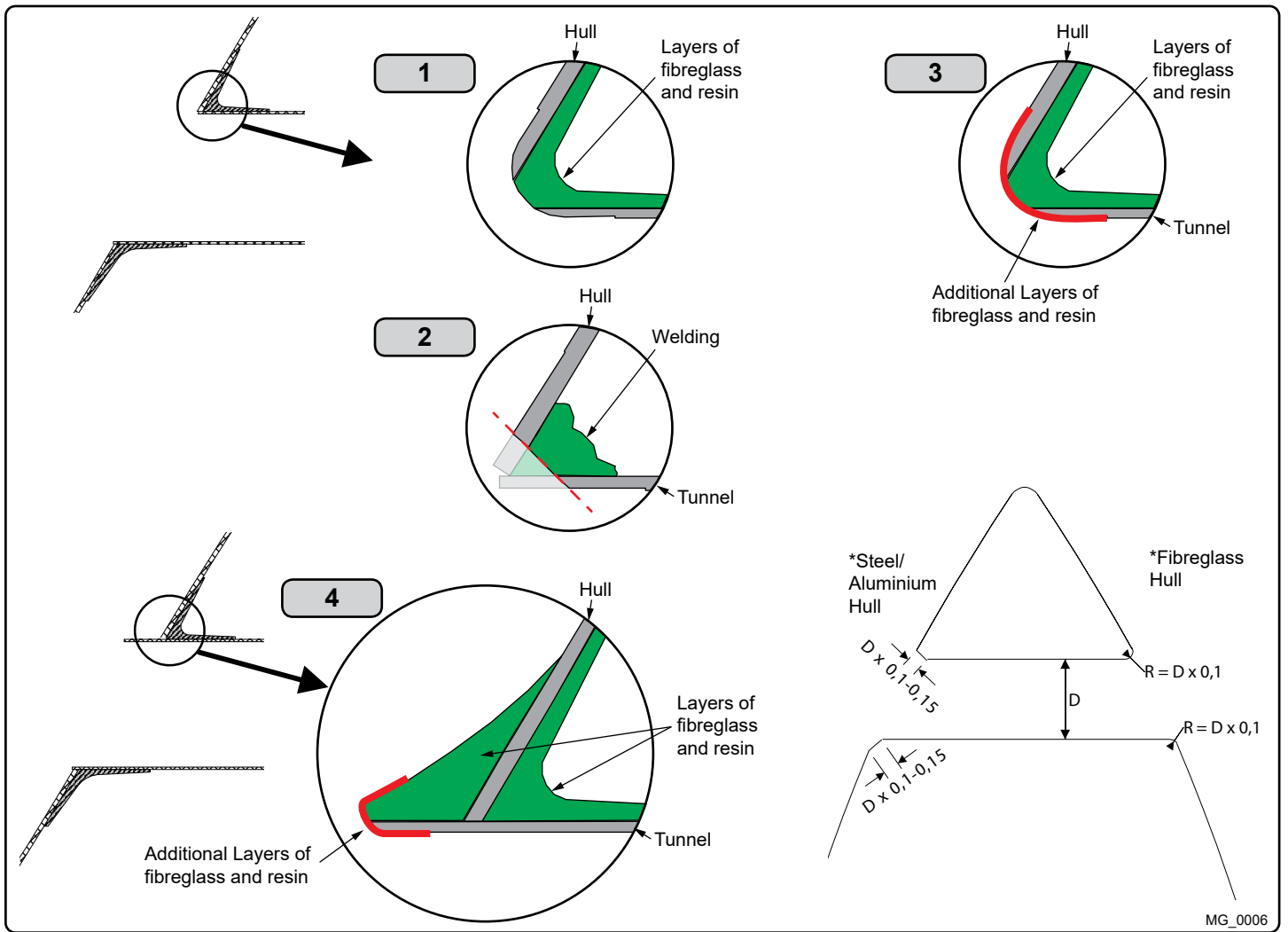

EN

## Tunnel installation

MC\_0003

With tunnel installed and cast.

1. Round the edges with a radius of 10% of the tunnel diameter.
2. For steel/ aluminium hulls make a slope with a length of 10-15% of the tunnel diameter.  
**(NB: If this is not possible, round the tunnel end as much as possible.)**
3. Additionally cast two layers on the outside of the tunnel/ hull in a 10cm area
4. Follow the same method if making the deflector/ spoiler.

You must apply gel coat to areas you have grounded/ moulded to make waterproof. These areas allow water access to the hull which is typically not waterproof without these applications outside. **(NB: All original Side-Power tunnels are fully waterproof when delivered except in the areas where you have cut and bonded it to the hull.)**

### IMPORTANT

**Avoid all casting where the motor-bracket is to be placed, as this will cause misfit and possible failure to the gear house.**

Stern thruster installation has extra considerations and precautions and thruster installation procedures.

See the attached manual supplied in the stern thruster kit



### It is the installers responsibility

When installing Side-Power equipment to follow the outlined regulations/ classification rules (electrical/ mechanical) according to international or special national regulations. Instructions in this guide cannot be guaranteed to comply with global electric/ mechanic regulations/ classification rules.

To follow all health and safety laws in accordance with their local outlined regulations/ classification rules.

Before installation, it is important that the installer reads this guide to ensure necessary acquaintance with this product.

The recommendations made in this manual are guidelines ONLY, and Sleipner Motor AS (Side-Power) strongly recommend that before installation, advice is obtained from a naval architect familiar with the particular vessel and regulations/ classifications.

This manual is intended to support educated/ experienced staff and is therefore not sufficient in all details for professional installation. *(NB: These instructions are only general instruction. If you are not skilled to do this work, please contact professional installers for assistance.)*

All electrical work must be done by a licensed professional.

**Faulty installation of the tunnel, thruster or panel will render all warranty given by Sleipner Motor AS void.**

MC\_0038

EN

## Planning Considerations and Precautions

MC\_0113

- Do not install the thruster in a position where you need to cut a stiffener/ stringer/ support for the hull integrity without checking with the boat builder this can be done safely.
- The motor, its components, contacts/ plugs or other joints in the control cables must be mounted so they will remain dry at all times.
- We advise painting the gear house and propellers with antifouling. **(NB: Do not paint the anodes, sealings, rubber fittings or propeller shafts)**
- Do not finish the inside of the tunnel with a layer of gelcoat/ topcoat or similar. There is only room for a thin coat of primer and two layers of anti-fouling between the tunnel and the propellers.
- Keep installation within advised measurements. The entire surface is hard coated seawater resistant aluminium. Do not damage or penetrate the coat.
- Install the oil tank higher than the pumps to ensure enough gravity feed and pressure for feed ports. **(NB: The height of oil levels in the hydraulic tank should be higher than the connected hydraulic pumps.)**
- Find a suitable location for the hydraulic tank installation for future maintenance accessibility. There must be enough space around the oil tank to change filters, fill oil and inspect gauges and indicators.

EN

## Hydraulic Thruster Installation Considerations and Precautions

MC\_0009

**Before installation, The installer must read this guide to ensure necessary acquaintance with this product.**

- If the height of the room you are installing the Side-Power is limited, it can be installed horizontally or at any angle in-between.
- The motor must be handled with care. Do not rest on the driveshaft.

**If an original Side-Power hydraulic system is NOT installed, please ensure the following:**

- Install an oil filter to keep the oil clean.
- Fit an oil cooler or use an oil tank to ensure the maximum oil temperature is 43 - 50 degrees Celcius.
- Hydraulic thrusters are supplied with hydraulic motors only.
- The installed hydraulic system is the responsibility of the fitter/ installer and must be within the limitations outlined in this manual to ensure no damage is caused to the thruster.
- The hydraulic valve must have flow and pressure limits that are either set within or can be adjusted to the limits of the thrusters capability.
- We strongly advise that a shock valve is fitted and set to 10% - 15% above the chosen maximum pressure set in the valve. This will prevent the system from being damaged if the propellers are blocked for any reason.
- It is required that a device is installed to ensure that the drive direction cannot be suddenly changed, as this can severely damage the gear house. **(NB: By adding an electronic time-lapse/delay safety on the electric control system or by using a valve that has this type of protection built in will prevent this issue. \*The required time delay is 1 second.)**

### IMPORTANT

**If installing S-link products DO NOT connect any other control equipment to the S-link controlled products except Side-Power original S-link products or via a Side-Power supplied interface product made for interfacing with other controls. Any attempt to directly control or at all connect into the S-link control system without the designated and approved interface will render all warranties and responsibilities for the complete line of Side-Power products connected void and null. If you are interfacing by agreement with Sleipner and through a designated Side-Power supplied interface, you are still required to also install at least one original Side-Power control panel to enable efficient troubleshooting if necessary.**

MC\_0265

			60 %		70 %		80 %		90 %		100 %	
			Flow	Pressure	Flow	Pressure	Flow	Pressure	Flow	Pressure	Flow	Pressure
<b>SH1000</b>	G70	L/min -Bar	91,0	220	99,0	256						
		USG-PSI	24.0	3190	26.2	3712						
	G75	L/min -Bar	98,0	205	106,0	239						
		USG-PSI	25.9	2973	28.0	3466						
	BA80	L/min -Bar	90,4	188	98,0	220	104,4	251	111,0	282		
		USG-PSI	23.9	2726	25.9	3190	27.6	3640	29.3	4089		
	BA90	L/min -Bar	99,5	167	107,0	195	115,0	225	122,0	251	128,5	279
		USG-PSI	26.3	2422	28.3	2828	30.4	3263	32.2	3640	40.0	4046
BA110	L/min -Bar	122,0	139	131,4	132	140,5	185	149,0	208	157,0	231	
	USG-PSI	32.2	2016	34.7	1914	37,1	2683	39.4	3016	41.5	3350	
<b>SH1400</b>	BA125	L/min -Bar	113,0	197	122,4	230	131,0	263	139,0	296		
		USG-PSI	29.9	2857	32.3	3335	34.6	3814	36.7	4292		
	BA150	L/min -Bar	139,0	164	150,0	192	160,4	219	170,0	247	179,4	274
		USG-PSI	36.7	2378	39.6	2784	42.4	3176	44.9	3582	47.4	3973
	BA160	L/min -Bar	145,0	154	157,0	180	167,5	205	178,0	231	187,0	257
		USG-PSI	38.3	2233	41.5	2610	44.3	2973	47.0	3350	49.4	3727
	BA180	L/min -Bar	163,0	137	176,0	160	188,5	183	200,0	205	211,0	228
		USG-PSI	43.0	1987	46.5	2320	49.8	2654	52.8	2973	55.7	3306
<b>SH 700</b>	BA40	L/min -Bar	57,0	224	61,5	261	66	298				
		USG-PSI	15,01	3249	16,3	3785	17,4	4322				
	BA45	L/min -Bar	64.0	196	69.0	229	73,5	261,0	78,0	294,0		
		USG-PSI	17,7	2843	18,2	3321	19,4	3785,0	20,6	4264,0		
	BA56	L/min -Bar	79,0	160	85.0	186	91	213,0	97,0	240,0	102,0	266,0
		USG-PSI	20,9	2321	22,5	2698	24	3089,0	25,6	3481,0	27,0	3858,0
	BA60	L/min -Bar	85.5	149	92.5	174	99	199,0	105,0	224,0	110,5	248,0
		USG-PSI	22,6	2161	24,4	2524	26,2	2886,0	27,7	3249,0	29,2	3597,0

## U, P &amp; G-motor:

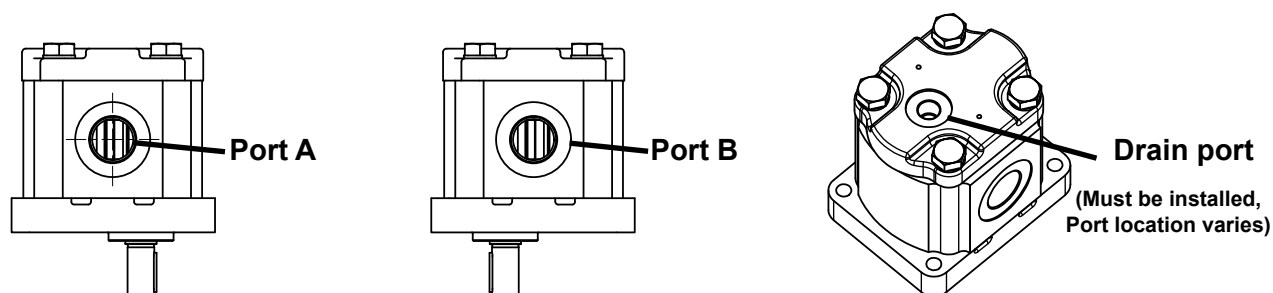

## BA-motor:

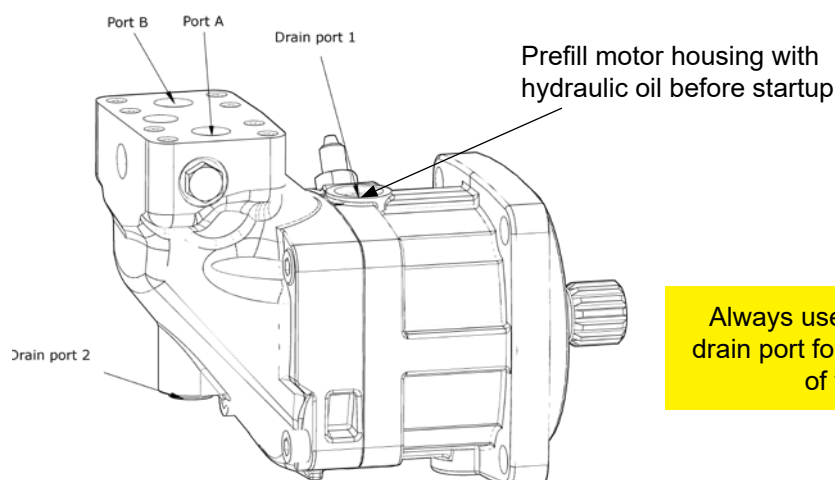

Always use upper positioned drain port for optimal lubrication of the motor.

Motor type	Port A/B	Port flange threads	Drain port
G70	1 1/4" BSP	-	1/4" BSP
G75	1 1/4" BSP	-	1/4" BSP
BA40	3/4" 6000 PSI SAE J518/ISO6162 Code 62	3/8" UNC-2B 20 deep	3/4" - 16 UNF
BA45	3/4" 6000 PSI SAE J518/ISO6162 Code 62	3/8" UNC-2B 21 deep	3/4" - 16 UNF
BA56	3/4" 6000 PSI SAE J518/ISO6162 Code 62	3/8" UNC-2B 21 deep	3/4" - 16 UNF
BA60	3/4" 6000 PSI SAE J518/ISO6162 Code 62	3/8" UNC-2B 22 deep	7/8" - 16 UNF
BA80	1" 6000 PSI SAE J518/ ISO 6162 Code 62	7/16-14 UNC-2B 19 deep	7/8"-14 UNF
BA90	1" 6000 PSI SAE J518/ ISO 6162 Code 62	7/16-14 UNC-2B 19 deep	7/8"-14 UNF
BA110	1 1/4" 6000 PSI SAE J518/ ISO 6162 Code 62	1/2-13 UNC-2B 19 deep	1 1/16-12 UNF
BA125	1 1/4" 6000 PSI SAE J518/ ISO 6162 Code 62	1/2-13 UNC-2B 19 deep	7/8"-14 UNF
BA160	1 1/4" 6000 PSI SAE J518/ ISO 6162 Code 62	1/2-13 UNC-2B 19 deep	7/8"-14 UNF
BA180	1 1/4" 6000 PSI SAE J518/ ISO 6162 Code 62	1/2-13 UNC-2B 19 deep	7/8"-14 UNF



# Crossover Valve

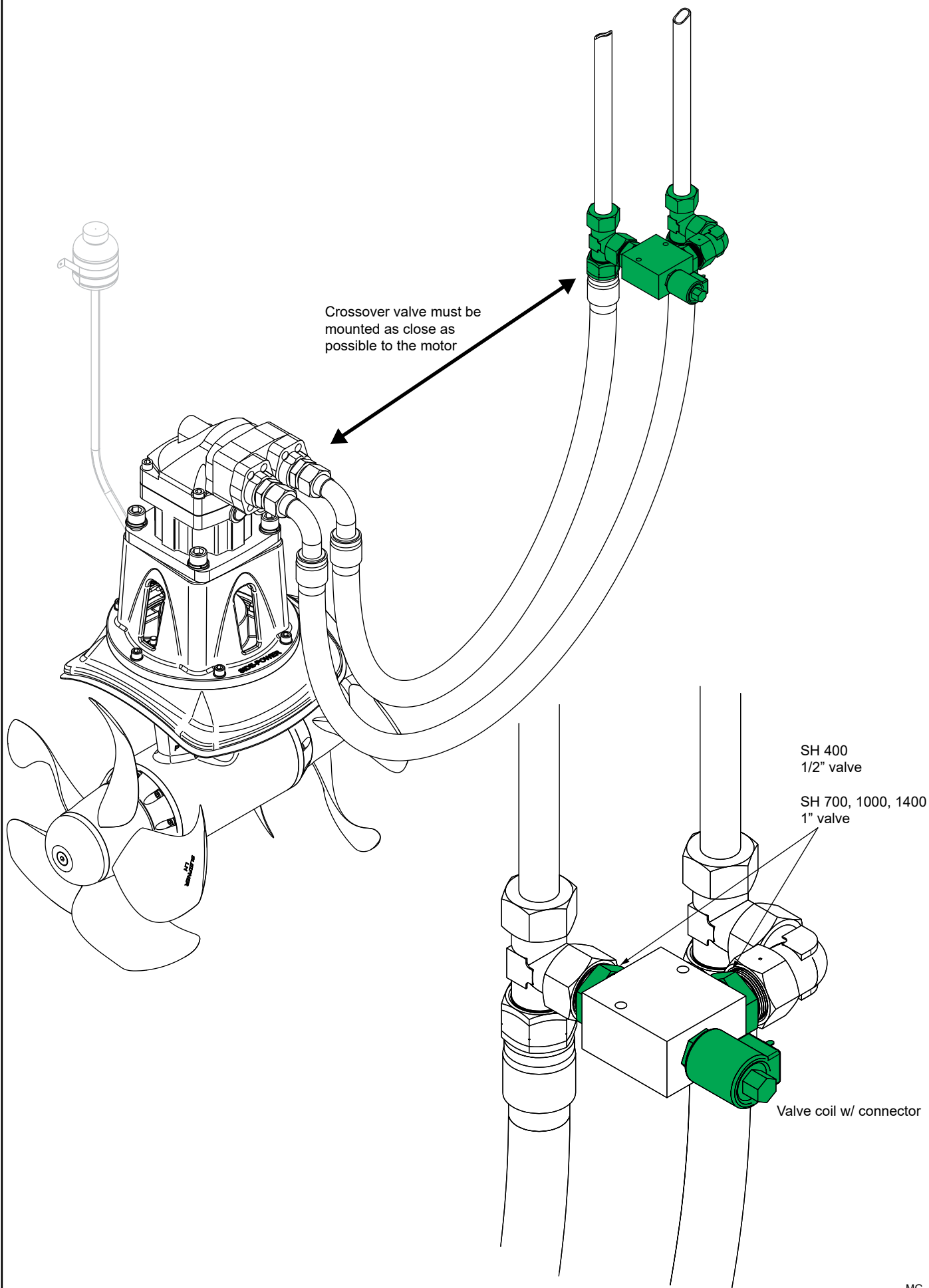

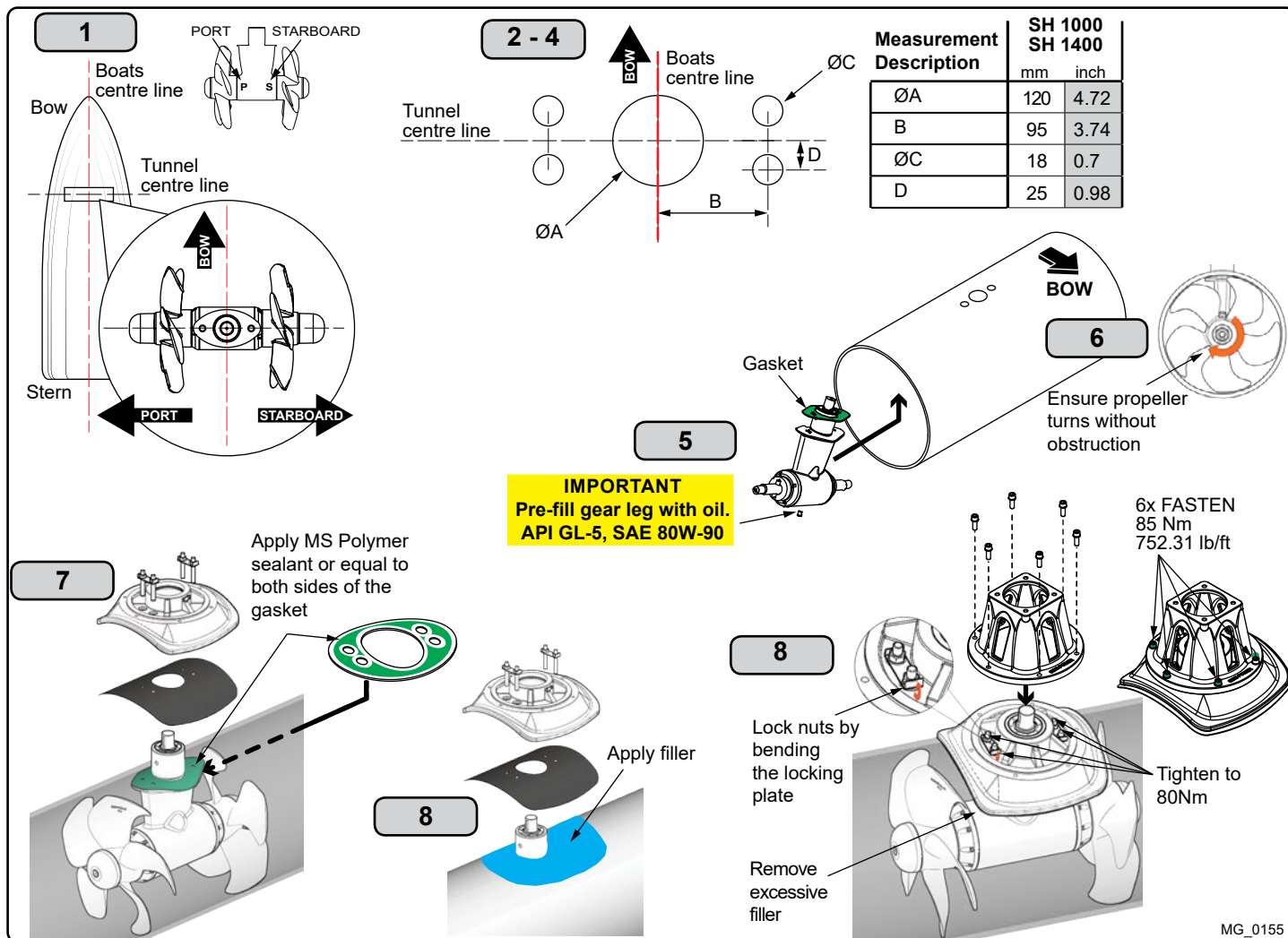

**EN Gear Leg & Motor Bracket Installation** MC\_0002

**! Please refer to the graphic for special considerations relating to your model !**

1. Mark the tunnel centreline and the boat's centreline. **(NB: Install the gear leg and propeller as shown above for the thrust direction to correspond with the control panel. Position gear leg with the P-mark facing port and the S-mark facing starboard.)**
2. Use the gasket or template (recommended) to mark the hole centres and double-check the measurements. The centre hole MUST be placed using the boat centreline as shown above. **(NB: All holes must be in-line with the tunnels' centreline for correct installation, clearance between the propeller and the tunnel is minimal.)**
3. Smooth the surface of the tunnel. A rough surface will cause possible failure/ movement of the gear leg. The motor bracket must rest steadily on the tunnel.
4. Drill the main centre hole followed by the two screw-holes.
5. Fill the gear leg with oil as shown above through the hole of the oil drain screw. Ensure to insert the copper gasket and fasten after adding oil into the gear leg.

**IMPORTANT**

**Ensure there is oil or grease on the O-rings in the motor bracket before mounting with the gearhouse. Nolubrication could cause serious damage to the O-rings. NB: The gear leg neck and the inner surface of the motor bracket must remain clean.**

6. Place the gear leg (without the propeller) with the gasket on inside the tunnel. Place the propeller on the gear leg to ensure it is centred and rotates freely with the same clearance from each blade to the tunnel wall. Place top motor bracket to measure the driveshaft has come through the motor bracket at the correct height. Remove the gear leg and propeller for final installation.
7. Apply appropriate sealant to both sides of the gasket and place on the gear leg. Place the gear leg in the tunnel (without the propeller).
8. Install the top motor bracket and gear leg gently together. Use appropriate filler to ensure that no leakages occur. **(NB: See your sealant datasheet for the correct application process.)**
9. Fasten the gear leg and the motor bracket with the bolts provided. Fasten to torque as shown above.

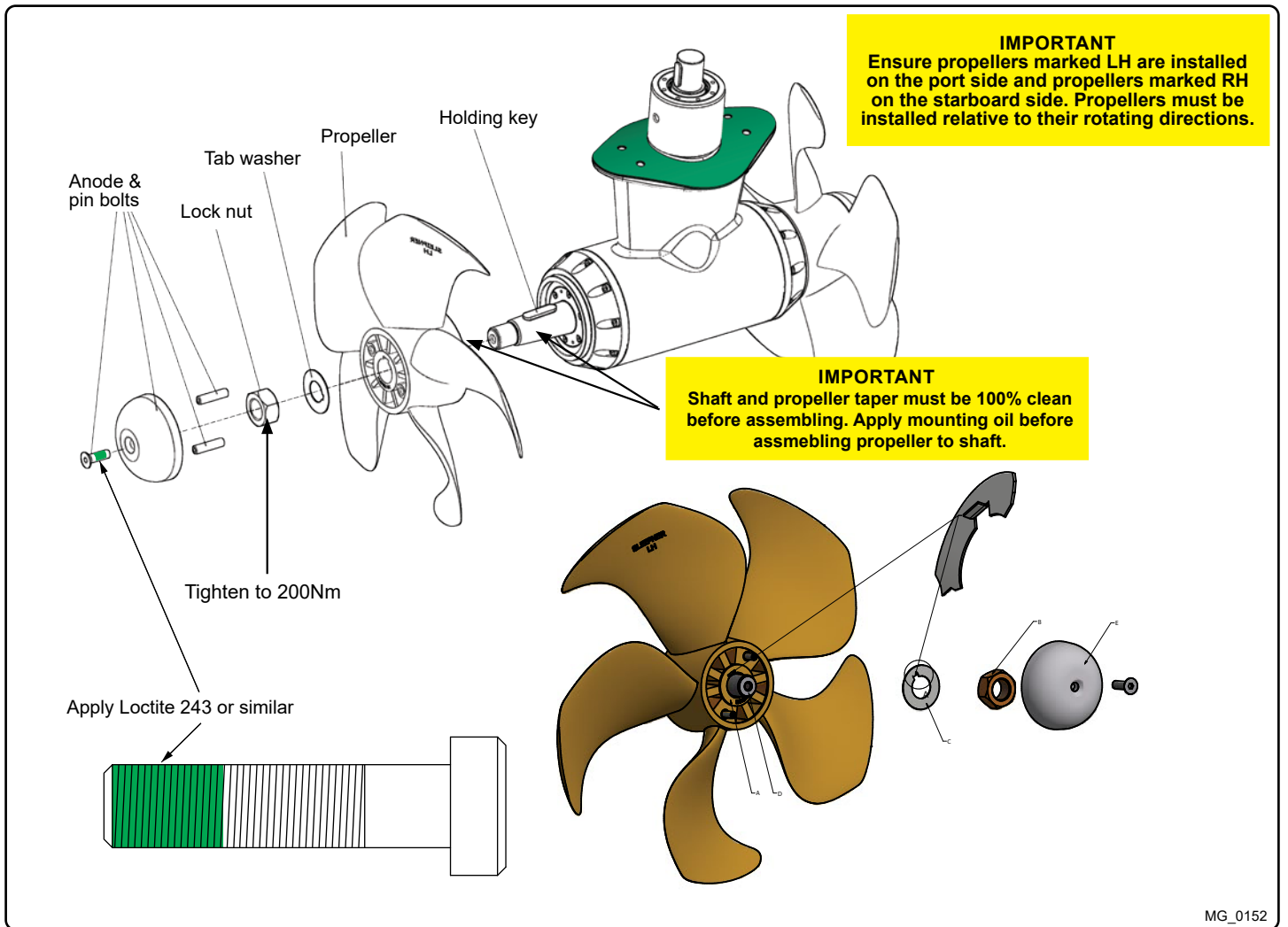

EN

## Propeller Installation

MC\_0022

**! Please refer to the graphic for special considerations relating to your model !**

1. Rotate the propeller shaft, so the propeller key is on top. Remove the tape holding the propeller key in its recess on the propeller shaft.
2. Insert the propeller onto the propeller shaft until the propeller key aligns into the slot/ groove in the propeller. **(NB: Installation requires almost no gap (approximately 1mm) between the propeller and the gear leg.)**
3. Apply waterproof grease only to the thread where the bolt will be fastened to achieve required torque tension. **DO NOT** apply grease to the internal propeller core.
4. Without the washer fasten the propeller lock-nut to the required torque.
5. Remove the propeller lock-nut from the shaft and grease the washer surface facing the propeller lock-nut.
6. Insert the washer on the propeller shaft and re-fasten the propeller lock-nut to required torque tension. **(NB: Ensure the washer tab is inserted into the slot/ groove in the propeller.)**
7. Insert the two anode pins on the propeller and the anode to the end of the propeller and fasten the anode holding screw. Apply a thread glue (Loctite or similar) to ensure that the anode holding screw does not un-screw itself from during the rotation of the propeller.

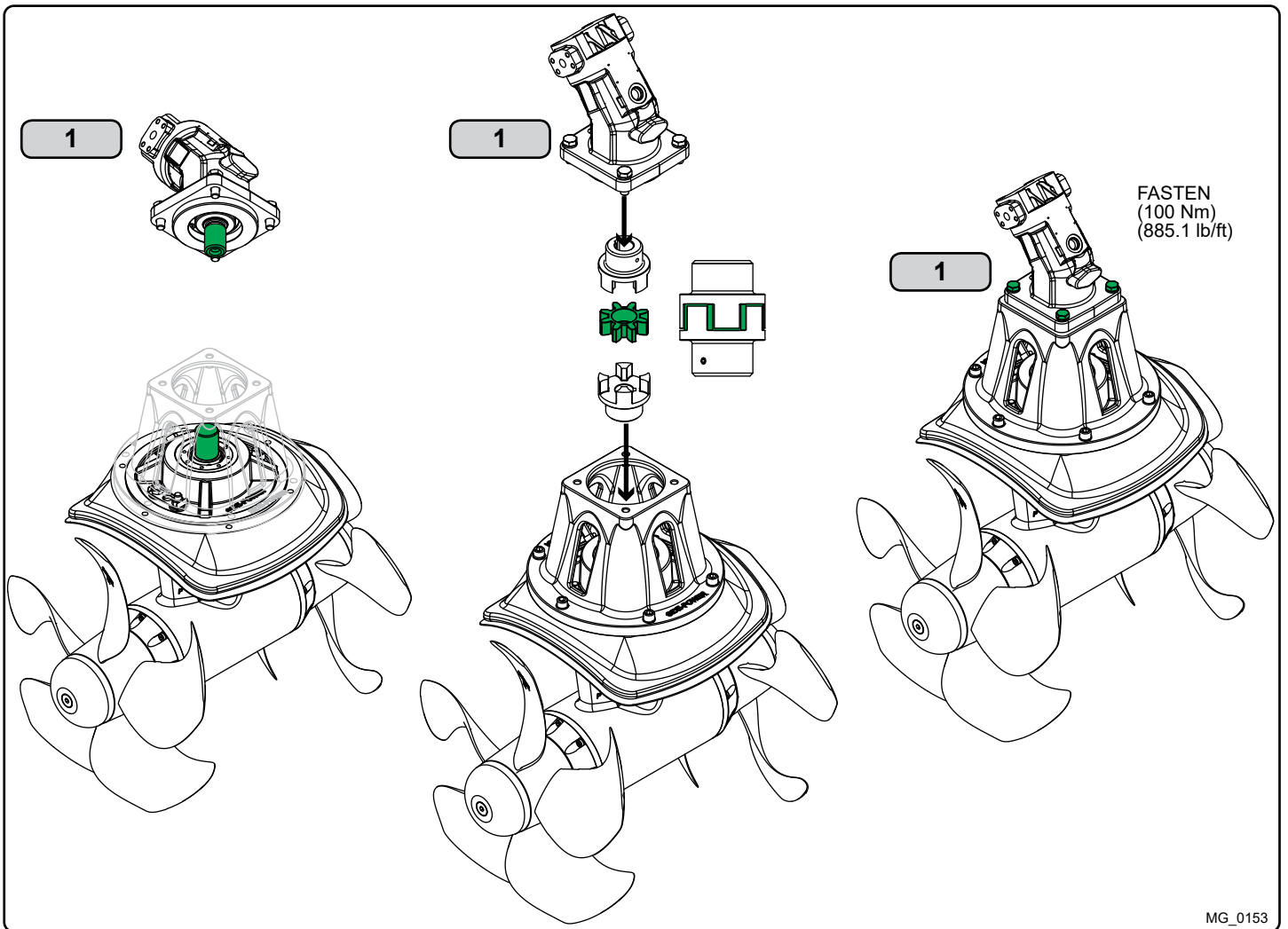

EN

## Motor Installation

MC\_0114

**! Please refer to the graphic for special considerations relating to your model !**

1. Install the motor onto the motor bracket ensuring the couplings are engaged together correctly (top and bottom). **(NB: The motor can be placed in all directions on the motor bracket. However, ensure the hose terminals are accessible for connection installation later.)**
2. Apply seawater resistant grease on the shafts before fitting the flexible coupling.
3. Insert the lower part of the flexible coupling and tighten the set screw. Measure the height of the upper flexible coupling on the motor shaft.
4. Fasten the coupling set screw to the lower flexible coupling and apply blue Loctite. **(NB: Ensure the axle key and keyway in the flexible coupling are aligned.)**
5. Install the motor onto the motor bracket ensuring the couplings are engaged together correctly (top and bottom). **(NB: The motor can be placed in all directions on the motor bracket. However, ensure the cable terminals are accessible for electrical installation later.)**
6. Fasten the bolts holding the motor to the motor bracket with the above torque.
7. Check the drive shafts are engaged by rotating the propeller. **(NB: Rotating the propellers can be hard due to the gear reduction and the motor, however the propeller must be able to rotate via hand power.)**

### IMPORTANT

**The hydraulic motor must be covered to avoid dust from fabrication/ maintenance operation entering the motor hose pipes.**

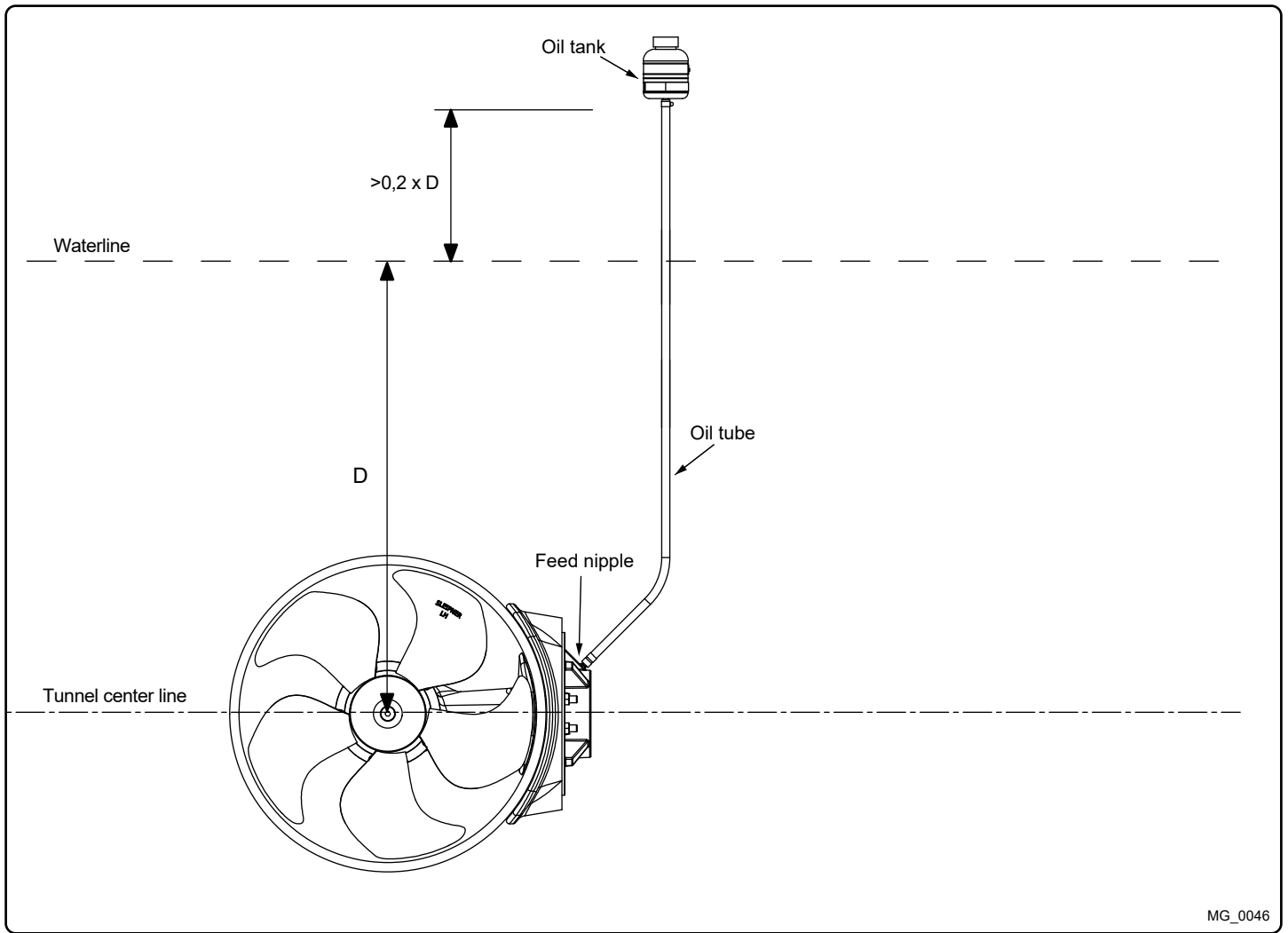

MG\_0046

EN

## Oil Tank Installation

MC\_0023

**! Please refer to the graphic for special considerations relating to your model !**

1. Install the oil tank above the waterline by at least 20% of the distance from the waterline to the centre of the tunnel. This ensures enough overpressure for the oil in the gear leg.
2. Install the oil tube from the tank oil tank to the feed nipple on the motor bracket. Fasten the two tube clamp screws. **(NB: Ensure the oil tube has no loops and forms an airlock to stop the oil flow. Ensure the oil tube angle is sufficient to allow oil to flow freely into the gear leg.)**
3. Fill the oil tank with the same gear oil used in the gear leg. The oil tank works as an indicator to ensure there is oil in the gear leg at all times.

**(NB: Fill and drain the gear leg simultaneously while replacing the oil to ensure the system is never empty.)**

Example of the control wiring with S-link system for boats with one control position and one thruster.

Control Panel



You need:

- 2 x 6 1327 End terminators
- 3 x 6 1326 T-connectors
- 1 x 6 1328 Power spur
- 2 x 6 1320-xxM Backbone cables
- 2 x 6 1321-xxM Spur cables

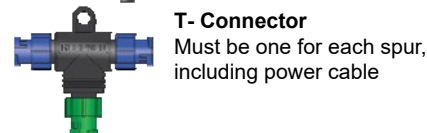
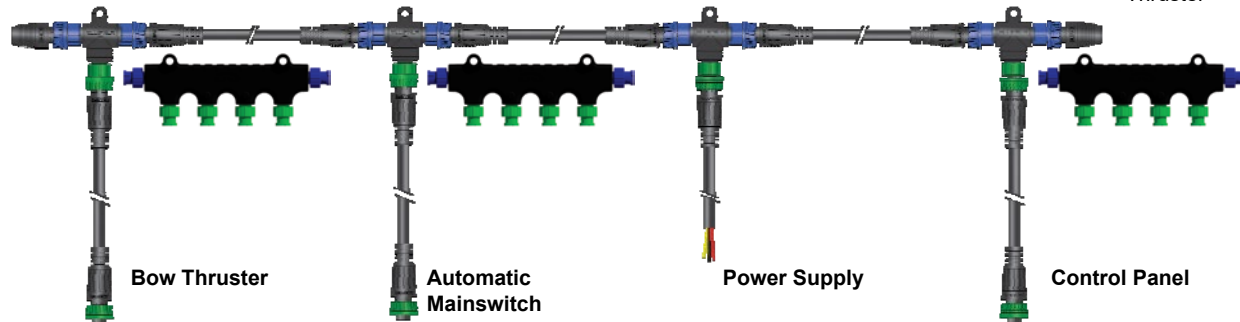
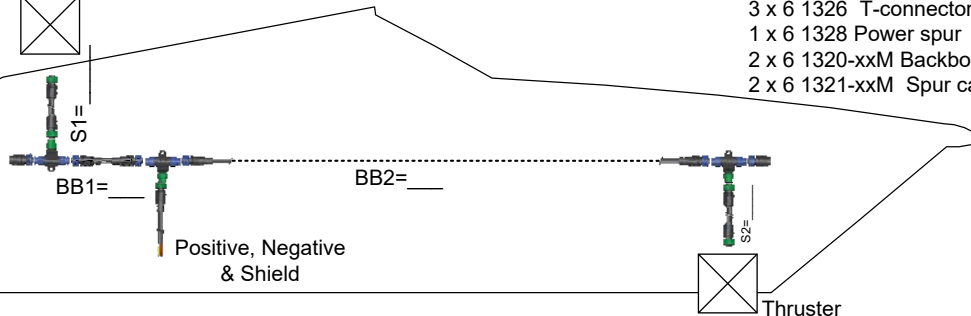

**T- Connector**  
Must be one for each spur, including power cable



**BACKBONE extender**  
Connects two BACKBONE cables to extend length.



**END terminator**  
Must be one for each end of the BACKBONE "loop".



**BACKBONE Cable**  
Forms the main "loop" around the boat.



**SPUR Cable**  
Must be used to connect all parts to the backbone cable (One for each component, no exceptions). Recommended to be as short as practically possible.



**POWER Cable**  
Must be one in each system, length 2.5m



**4-Port T Connector**  
The 4-port T-connector allows multiple spur cables to be connected. *(NB: Comes with two sealing caps to protect.)*

MG\_0159

EN

## S-link Planning & Precautions

MC\_0120

S-link is a "CAN" based control system with full intelligent communication between all units in the system.

Main advantages include:

- Round, compact and waterproof plugs with unique keying and colour coding to avoid faulty hookup.
- An unlimited number of commands or information transfer on a single cable.
- Proprietary Sleipner commands but built 100% on NMEA 2000 standard.

### Routing the Backbone:

Keep routing backbone spur cables to a minimum. Avoid routing the S-link cables close to equipment that might cause interference to the S-link signals such as radio transmitter equipment, antennas or high voltage cables. The backbone MUST be terminated at each end with the 6 1327 End Terminator.

### Spur cables:

Spur cables can be left unterminated *(NB: Routing can be prepared for future additional equipment)*. Make sure to protect open connectors from water and moisture to avoid corrosion in the connectors.

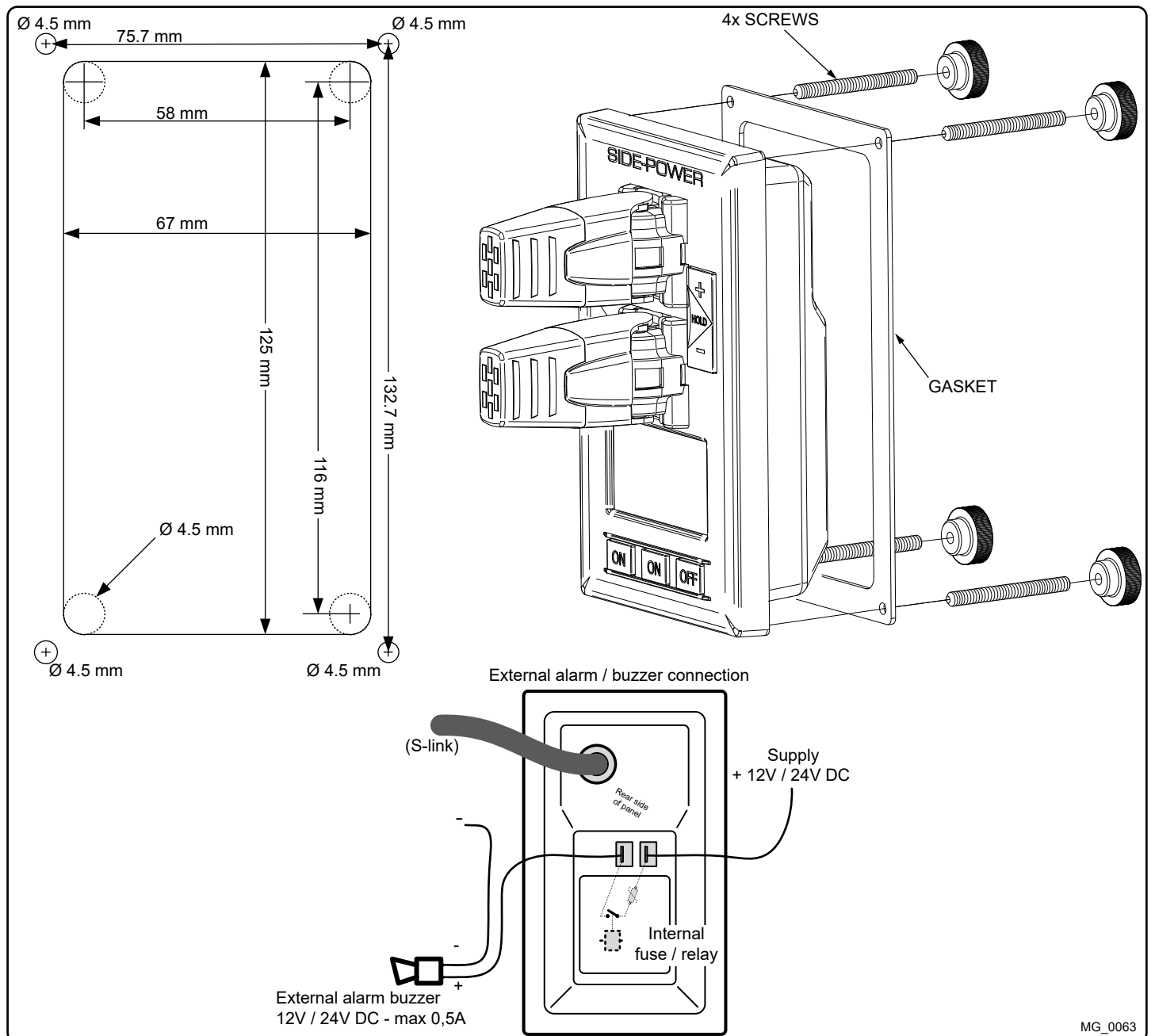

## Control Panel Installation

MC\_0042

**! Please refer to the graphic for special considerations relating to your model !**

Find a suitable location for the control panel where it does not obstruct or is obstructed by other devices. Install the control panel on a flat surface where it is easy to use.

1. Use the supplied cut-out template to mark the area to remove on your control dash.
2. Cut out the area per template for the control panel. **(NB: If the front surface around your cut out is jagged or chipped, use a sealant to assist the gasket.)**
3. Place the gasket to the back face of the panel
4. Plug cables into the connectors at the rear of the control panel.
5. Insert the control panel in place and fasten screws.
6. Insert the control panels covering caps.

- ..... Propeller is fastened correctly to the shaft.
- ..... Propeller turns freely in tunnel.
- ..... Lower-unit is filled with gearoil.
- ..... Oil-drain screw is tightened and the copper seal is present.
- ..... The anode holding screw is tightened well with thread glue.
- ..... Anti-fouling have been applied to the gearhouse and propeller but NOT on the anode or the gearhouse lid where the propeller is fastened.
- ..... Oil tank is fitted above the waterline as required and filled with gearoil.
- ..... Correct drive direction as per controlpanel.
- ..... The bolts holding the gearhouse and motorbracket together are tightened correctly.
- ..... The bolts holding the motor to its bracket are tightened correctly.

The thruster has been installed as per the instructions in this manual and all points in checklist above have been controlled.

Signed: .....

Date: .....

Extra pre-delivery tests by installer / yard who does not use other quality control systems !

Thruster type: .....

Serial number:.....

Date of delivery:.....

Correct drive direction as per controlpanel: .....

The compartment for the thruster has been isolated from general bilge water and has no obvious or suspected risks for flooding:

.....  
.....  
.....

Other comments by installer: .....

.....



**For the most up to date documentation, we advise you to visit our website [www.side-power.com](http://www.side-power.com) for the spare parts list.**

1. The equipment manufactured by Sleipner Motor AS (The "Warrantor") is warranted to be free from defects in workmanship and materials under normal use and service.
2. This Warranty is in effect for of two years (Leisure Use) or one year (Commercial use) from the date of purchase by the user. Proof of purchase must be included, to establish that it is inside the warranty period.
3. This Warranty is transferable and covers the product for the specified time period.
4. In case any part of the equipment proves to be defective, other than those parts excluded in paragraph 5 below, the owner should do the following:
  - (a) Prepare a detailed written statement of the nature and circumstances of the defect, to the best of the Owner's knowledge, including the date of purchase, the place of purchase, the name and address of the installer, and the Purchaser's name, address and telephone number;
  - (b) The Owner should return the defective part or unit along with the statement referenced in the preceding paragraph to the warrantor, Sleipner Motor AS or an authorized Service Centre, postage/shipping prepaid and at the expense of the Purchaser;
  - (c) If upon the Warrantor's or Authorized Service Centre's examination, the defect is determined to result from defective material or workmanship, the equipment will be repaired or replaced at the Warrantor's option without charge, and returned to the Purchaser at the Warrantor's expense;
  - (d) no refund of the purchase price will be granted to the Purchaser, unless the Warrantor is unable to remedy the defect after having a reasonable number of opportunities to do so. Prior to refund of the purchase price, Purchaser must submit a statement in writing from a professional boating equipment supplier that the installation instructions of the Installation and Operation Manual have been complied with and that the defect remains;
  - (e) warranty service shall be performed only by the Warrantor, or an authorized Service Centre, and any attempt to remedy the defect by anyone else shall render this warranty void.
5. There shall be no warranty for defects or damages caused by faulty installation or hook-up, abuse or misuse of the equipment including exposure to excessive heat, salt or fresh water spray, or water immersion except for equipment specifically designed as waterproof.
6. No other express warranty is hereby given and there are no warranties which extend beyond those described in section 4 above. This Warranty is expressly in lieu of any other expressed or implied warranties, including any implied warranty of merchantability, fitness for the ordinary purposes for which such goods are used, or fitness for a particular purpose, and any other obligations on the part of the Warrantor or its employees and representatives.
7. There shall be no responsibility or liability whatsoever on the part of the Warrantor or its employees and representatives for injury to any person or persons, or damage to property, loss of income or profit, or any other consequential or resulting damage or cost which may be claimed to have been incurred through the use or sale of the equipment, including any possible failure or malfunction of the equipment, or part thereof.
8. The Warrantor assumes no liability for incidental or consequential damages of any kind including damages arising from collision with other vessels or objects.
9. This warranty gives you specific legal rights, and you may also have other rights which vary from country to country.

Area with horizontal dotted lines for writing notes.

Area with horizontal dotted lines for notes.

# Worldwide sales and service



[www.side-power.com](http://www.side-power.com)



SLEIPNER MOTOR \* AS P.O. Box 519 \* N-1612 Fredrikstad \* Norway

The information given in the document was correct at the time it was published. However, Sleipner Motor AS can not accept liability for any inaccuracies or omissions it may contain. Continuous product improvement may change the product specifications without notice. Therefore, Sleipner Motor AS can not accept liability for any possible differences between product and document.

MC\_0030