



SIDE-POWER Thruster Systems

SR

- 130/250 L&V

- 170/250 L&V

- 210/250 V

- 250/300 V

Installation Manual

*170/250

*210/250

*250/300



SLEIPNER MOTOR AS

P.O. Box 519

N-1612 Fredrikstad

Norway

www.side-power.com

Document id: 2882

Revision: 16

Date: 2020



Made in Norway

© Sleipner Motor AS 2020

Planning Installation Considerations and Precautions	3
Thruster Measurements	4
Thruster Specifications	5
Technical Specifications	5
Positioning of the Retract Thruster	6

Installation Instructions

Thruster Installation Considerations and Precautions	7
Marking and Trimming of SRF Flange	8
Installation Pre-check	9
Required Modifications After Pre-check	10
SRF Flange Installation	11
Motor House Installation	12
Hatch Installation	13
Motor to House Installation	14
Thruster Electrical Installation	15
Electrical Specifications	16
Control Panel Cable Installation	17
S-link Planning & Precautions	18
Technical Wiring Diagram	19
Visual Wiring Diagram	20
Check drive shaft alignment	21
Calibrate drive shaft alignment	21
Actuator Configuration	21
LED Indication	21
Control Panel Installation	22

Checklist for DC and IP Thrusters	23
--	-----------

Spare Parts	24
--------------------------	-----------

Warranty statement	24
---------------------------------	-----------

Products

SRV170/250TC - SRV170 Vertical Retract 24V
 SRVP170/250TC - SRVP170 Vertical Retract 24V
 SRV210/250TC - SRV210 Vertical Retract 24V
 SRV130/250T-12V - SRV130 Vertical Retract 12V
 SRV130/250T-24V - SRV130 Vertical Retract 24V
 SRL130/250T-24V - SRL130 Retract thruster 24V
 SRL170/250TC-IP - SRL170 Retract thruster 24V
 SRL130/250T-12V - SRL130 Retract thruster 12V

DECLARATION OF CONFORMITY

MC_0020

CE Sleipner Motor AS
 P.O. Box 519, Arne Svendsensgt. 6-8
 N-1612 Fredrikstad, Norway

Declare that this product with accompanying standard control systems complies with the essential health and safety requirements according to:

DIRECTIVE 2013/53/EU
 DIRECTIVE 2014/30/EU
 DIRECTIVE 2014/35/EU

It is the installers responsibility

When installing Side-Power equipment follow the outlined regulations/ classification rules (electrical/ mechanical) according to international or special national regulations. Instructions in this guide cannot be guaranteed to comply with global electric/ mechanic regulations/ classification rules.

Follow all health and safety laws in accordance with their local outlined regulations/ classification rules.

Before installation, it is important that the installer reads this guide to ensure necessary acquaintance with the product.

The recommendations made in this manual are guidelines ONLY, and Sleipner Motor AS (Side-Power) strongly recommend that before installation, advice is obtained from a naval architect familiar with the particular vessel and regulations/ classifications.

This manual is intended to support educated/ experienced staff and is therefore not sufficient in all details for professional installation. *(NB: These instructions are only general instruction. If you are not skilled to do this work, please contact professional installers for assistance.)*

All electrical work must be done by a licensed professional.

Faulty installation of Sleipner products will render all warranty given by Sleipner Motor AS void.

MC_0038

EN

Planning Installation Considerations and Precautions

MC_0066

- If the height of the room you are installing the Side-Power is limited consider the three different configuration designs.
 - Angled
 - Horizontal
 - Vertical
- The thruster must NOT be installed in compartments that require ignition proof electric equipment. If necessary, make a separate compartment. ***(NB: If installing an IP assembly, it has been tested to be fully ignition protected so that it can be installed in areas with possible explosive gases in accordance with ISO 8846)***
- The electro motor will generate some carbon dust so any storage compartment must be separated from the thruster to prevent nearby items from becoming dusty/ dirty. ***(NB: IP version motors do not generate dust)***
- Installing the electro motor in a small compartment must be ventilated to ensure cooling of the electro motor.
- Do not install the thruster in a position where you need to cut a stiffener/ stringer/ support for the hull integrity without checking with the boat builder this can be done safely.
- The electro motor, its components, contacts/ plugs or other joints in the control cables must be mounted so they will remain dry at all times.
- We advise painting the gear house and propellers with anti-fouling. ***(NB: Do not paint the anodes, sealing or propeller shafts)***
- Do not finish the inside of the tunnel with a layer of gel-coat/ topcoat or similar. There is only room for a thin coat of primer and two layers of anti-fouling between the tunnel and the props.
- Don't install the electro motor at close range to easily flammable objects as it will reach over 100°C before the temperature switch is activated.
- Do not store items close to the thruster motor as it can reach 100°C. Any loose items near the thruster motor can cause problems with electrical wiring coming loose and short-circuiting.

IMPORTANT

Stern mounted retract thrusters must not be installed to conflict with the main boat propellers or its water trail. (NB: consult a naval architect for an exact position.)

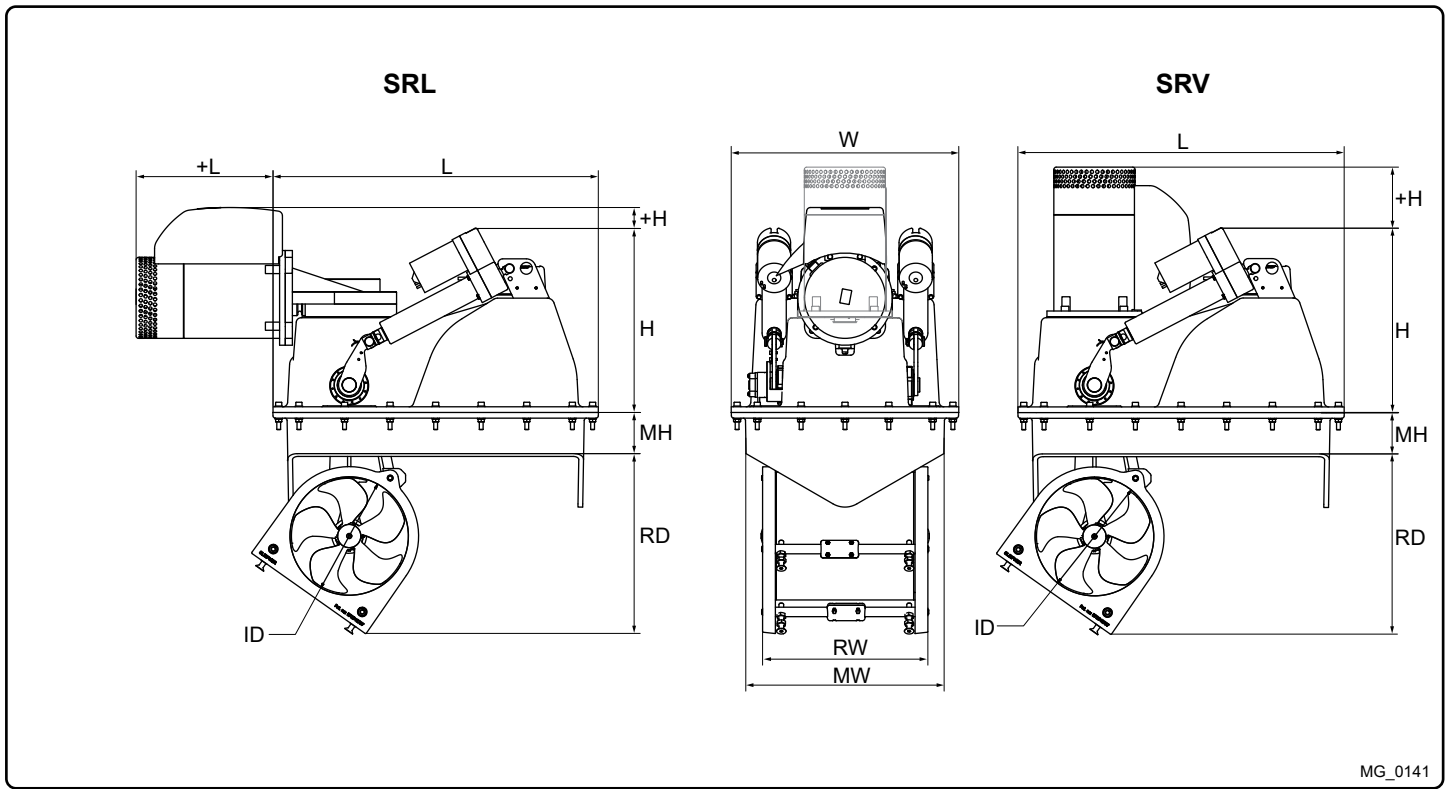

MG_0141

EN **Thruster Measurements** **MC_0151**

Measurement code	Measurement description	SRL *130 12v		SRL *130 24v		SRL *170 24v	
		mm	inch	mm	inch	mm	inch
+L	Motor supplementary measurement (Length)	264	10.39	269	10.59	289	11.38
L	SRF flange & motor housing length	688	27.09	688	27.09	688	27.09
+H	Motor supplementary measurement (Height)	23	0.91	23	0.91	44	1.73
H	Motor housing height	391	15.39	390	15.35	389	15.31
MH	SRF flange height	93	3.66	93	3.66	93	3.66
RD	Retracted hatch supplementary measurement	374	14.72	374	14.72	374	14.72
ID	Tunnel diameter	250	9.84	250	9.84	250	9.84
W	SRF flange & motor housing width	480	18.90	480	18.90	480	18.90
RW	Retracted hatch width	348	13.70	348	13.70	348	13.70
MW	SRF flange inner frame width	420	16.54	420	16.54	420	16.54

Measurement code	Measurement description	SRV *130 12v		SRV *130 24v		SRV *170 24v		SRV *210 24v		SRV *250 24v	
		mm	inch	mm	inch	mm	inch	mm	inch	mm	inch
+L	Motor supplementary measurement (Length)	0	0.00	0	0.00	0	0.00	0	0.00	0	0.00
L	SRF flange & motor housing length	688	27.09	688	27.09	688	27.09	688	27.09	843	33.19
+H	Motor supplementary measurement (Height)	104	4.09	110	4.33	128	5.04	211	8.31	172	6.77
H	Motor housing height	390	15.35	390	15.35	390	15.35	389	15.31	452	17.80
MH	SRF flange height	93	3.66	93	3.66	93	3.66	93	3.66	115	4.53
RD	Retracted hatch supplementary measurement	374	14.72	374	14.72	374	14.72	374	14.72	374	14.72
ID	Tunnel diameter	250	9.84	250	9.84	250	9.84	250	9.84	300	11.81
W	SRF flange & motor housing width	480	18.90	480	18.90	480	18.90	480	18.90	580	22.83
RW	Retracted hatch width	348	13.70	348	13.70	348	13.70	348	13.70	415	16.34
MW	SRF flange inner frame width	420	16.54	420	16.54	420	16.54	420	16.54	480	18.90

*Valid for SE & SEP

Description	* 130	* 170	* 210	* 250
Available DC System (v)	12v & 24v	24v	24v	24v
Thrust 12v or 24v (kg * lbs)	160 kg * 352 lbs	210 kg * 462 lbs	250 kg * 550 lbs	300 kg * 661 lbs
Thrust 10.5v or 21v (kg * lbs)	130 kg * 284 lbs	170 kg * 374 lbs	210 kg * 462 lbs	250 kg * 551 lbs
Typical Boat Size (m * ft)	13m - 19m * 42ft - 62ft	15m - 22m * 50ft - 70ft	17m - 24m * 55ft - 78ft	18m - 25m * 60ft - 84ft
Propulsion System	Twin	Twin Counter Rotating	Twin Counter Rotating	Twin Counter Rotating
Power (kw * Hp)	6.5kw * 8.7hp	8kw * 11.8hp	10kw * 13.15hp	11.4kw * 15.5hp
Weight (kg * lbs)	82 kg * 181 lbs	88 kg * 194 lbs	112 kg * 247 lbs	117 kg * 257 lbs
Minimum Battery Capacity (CCA) 12v * 24v * 48v	750 * 400	550	650	700
Installation	Flange	Flange	Flange	Flange

*Valid for SE / SE IP & SEP / SEP IP

- Motor:** Custom made reversible DC-motor.
- Gear house:** Seawater resistant bronze. Ball-bearing at propeller shaft and a combination of ball bearing and slide bearing at drive shaft. (Pre-filled and sealed for life)
- Motor bracket:** Seawater resistant aluminium, galvanically insulated from the motor..
- Tunnel:** Cross spun with rowing G.R.P tunnel
- Propeller:** 5-blade skewback "Q-prop" propeller, fibreglass reinforced composite.
- Batteries:** Minimum recommended battery capacity (cold crank capacity by DIN/SAE standard)
Contact a battery supplier for more information.
- Max. use:** 2 - 3 min. duty cycle at 20°
- Safety features:**
- Electronic time-lapse device protects against sudden change of drive direction.
 - The electric thermal cut-off switch in electro motor protects against overheating (auto-reset when electro motor cools down).
 - Flexible coupling between electro-motor and drive shaft protects electro motor and gear system if propeller jams.
 - Original Sidepower panels shut off automatically 6 minutes after last use.
 - Original Sidepower panels use child-safe double ON buttons.
 - An integrated microprocessor monitors solenoids, reduce wear and risk of solenoid lock-in.
 - Auto-stop of the thruster occurs when an undesirable solenoid lock-in occurs or when continuous operation cut-off timer exceeds 3 minutes.

Depending on the panel type after a certain time not in use, the console will shut down and retract the thruster.

(NB: the thruster will retract automatically when turned off.)

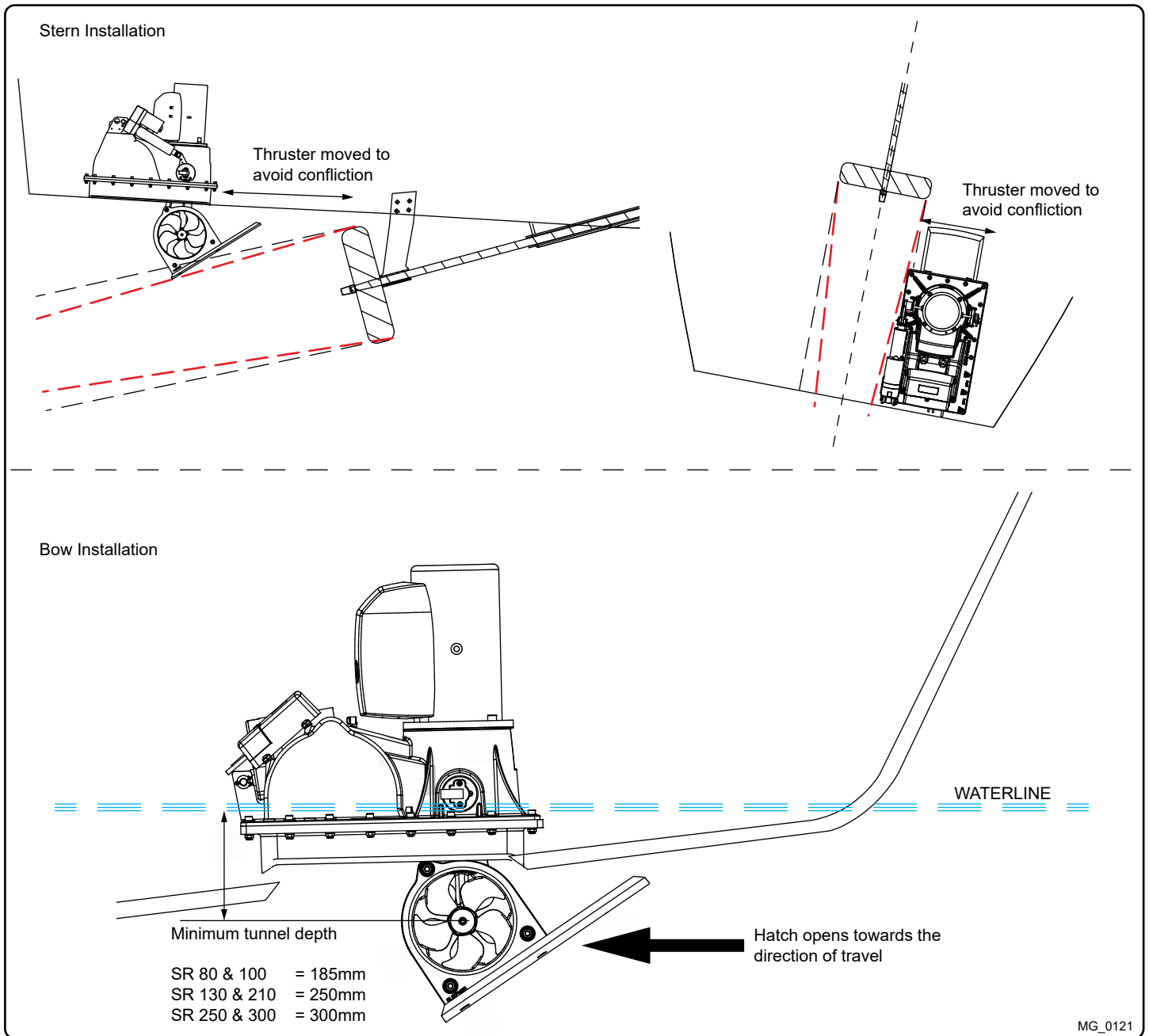

Positioning of the Retract thruster

MC_0067

The thruster must always be installed so the hatch is opened towards the direction of travel.

Bow

The thruster must be installed as far forward as possible. Allow for 10cm around the thruster for moulding the retract frame and the depth of the retracted propeller is 185mm (SR 80/100), 250mm (SR 130/210) or 300mm (SR 250/300) under the waterline. For bow installations, the thruster must be installed in the centre line of the keel. **(NB: Installing the thruster further forward will give less depth for the propeller but offer better leverage effect for turning.)**

Stern

Follow the same depth requirement for the retracted propeller of 185mm (SR 80/ 100), 250mm (SR 130/ 210) or 300mm (SR 250/ 300) under the waterline. The thruster while retracted must not conflict with any other component of the vessel such as stern drives/ propellers, trim tabs or rudders. Therefore stern installations do not require to be installed on the hulls keel centre line and can be installed off centre.

Installing the thruster below the waterline as outlined is important for two reasons:

1. So that it does not suck air down from the surface which will reduce performance and increase noise levels.
2. To get as much water pressure as possible to receive maximum efficiency from the thruster.

Always ensure enough space for the complete SR unit including motor, actuators, retract frame, future service and for installation moulding to the hull.

Before installation, it is important that the installer reads this guide to ensure necessary acquaintance with this product.

- The electro motor must be handled with care. Do not lift it by internal connections/ main terminals or placed down on the drive shaft.
- With the boat on land, run the thruster for short bursts.
- While the thruster is in the air, ensure that the propellers have come to a complete stop before performing a directional change of the thruster, as it might cause damage to the thruster.
- It is important to follow the guidelines in this manual. Failure can result in sever damage to the thruster.

DC Ignition Protected Thrusters:

- If there is a problem with your Ignition Protected stern thruster, please contact your dealer.

NEVER

Disassemble any part of the Ignition Protected stern thruster assembly. Tampering with the Ignition Protected stern thruster assembly or any attempt to disassemble anything on this thruster assembly inside the boat can cause an explosion with severe consequences.

IMPORTANT

If installing S-link products DO NOT connect any other control equipment to the S-link controlled products except Side-Power original S-link products or via a Side-Power supplied interface product made for interfacing with other controls. Any attempt to directly control or at all connect into the S-link control system without the designated and approved interface will render all warranties and responsibilities for the complete line of Side-Power products connected void and null. If you are interfacing by agreement with Sleipner and through a designated Side-Power supplied interface, you are still required to also install at least one original Side-Power control panel to enable efficient troubleshooting if necessary.

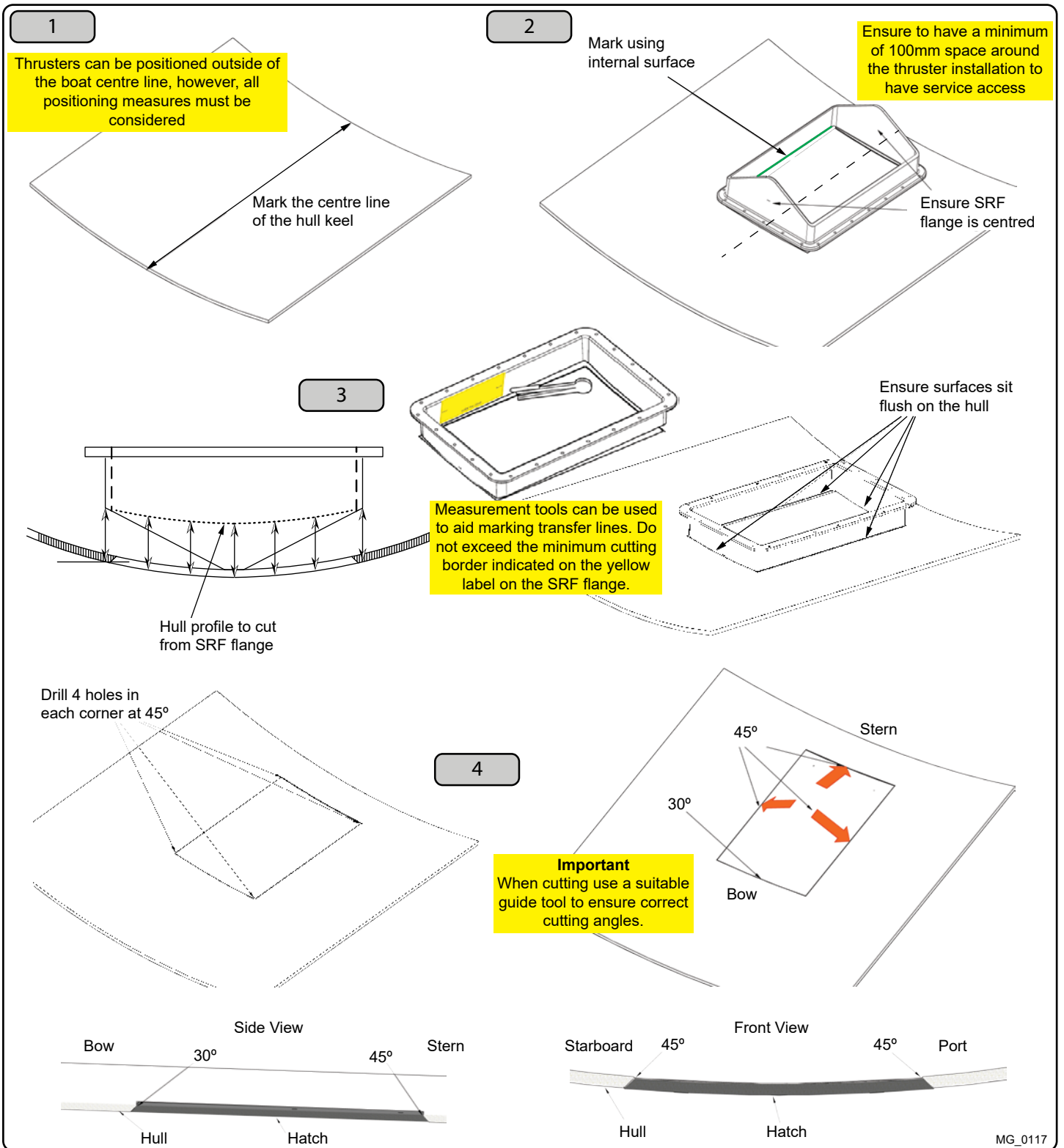

EN **Marking and Trimming of SRF Flange** **MC_0068**

! Please refer to the graphic for special considerations relating to your model !

1. Identify the location of the thruster considering space required for installation, operation and future maintenance.
2. Mark the keel centre line on the inside of the hull. Flip the SRF flange upside down and use the internal surface to mark the hull for cutting the thruster hatch. **(NB: Ensure the mould is centred.)**
3. The SRF flange must sit so the two side rails run flush with the length of the hull. To do so the SRF flange tabs must be trimmed down to match the hull profile curvature. **(NB: Consult a naval architect for methods to transfer the hull profile to the SRF flange. DO NOT cut the SRF flange length edge.)**
4. Cut the hatch door. The hatch opening must be cut at an angle of 45° on three sides and 30° on the bow face. This allows any water forces hitting the hatch while closed to be absorbed by the hull, not the thruster. **(NB: Use a suitable cutting tool able to be set to the desired angle. If cutting from outside the hull drill 4 holes from the internal marked corners to see the required profile from the outside.)**

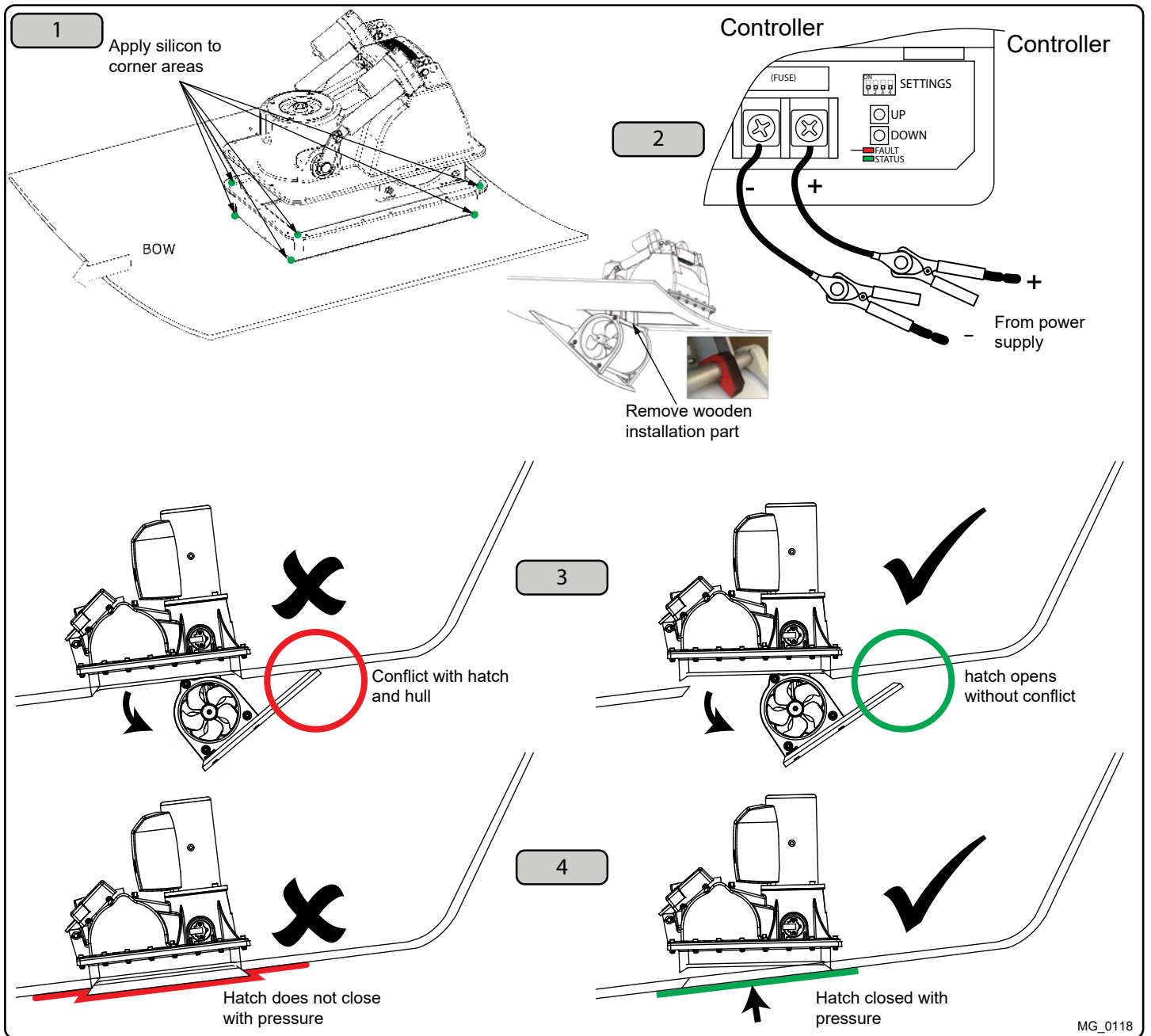

MG_0118

EN

Installation Pre-check

MC_0068

! Please refer to the graphic for special considerations relating to your model !

Temporarily set up the complete installation to ensure no conflicts during the final operation of the thruster.

1. Use silicon in the 4 corners of the SRF flange and set it over the hatch. Attach the motor unit to the SRF flange with 4 corner screws to hold securely in place. use silicon to attach the hatch to the propeller unit. **(NB: Ensure correct orientation for the thruster to open the hatch facing the direction of water flow. Remember attachment is for temporary checking of thruster operation only.)**
2. Temporarily connect 12 or 24 DC cables (refer to the label on actuators for correct voltage) to the 6 mm cables on the terminals on the controller. Set switch no. 4 on the DIP-switch marked "SETTINGS" to ON. Remove the wooden safety part located above the propeller.
3. Press "DOWN" to extend the retract mechanism and check the hatch opens fully without touching the hull. If the hatch is obstructed by the hull, lift the aft end of the SRF flange maintaining the reference height in front - until the hatch clears the hull when opened.
4. Press "UP" to retract the propeller mechanism. Ensure when the hatch is closed extra pressure is on the contact surface between the hatch and the hull only. If the hatch is not closing with pressure on the contact surfaces the entire SRF flange must be raised.

After all, pre-checks are completed the SR system can be installed.

IMPORTANT

The hatch contact edges and the hull contact edges MUST work as the mechanical end stop. During cruising, slamming forces from the water must be absorbed by these areas, not the thruster.

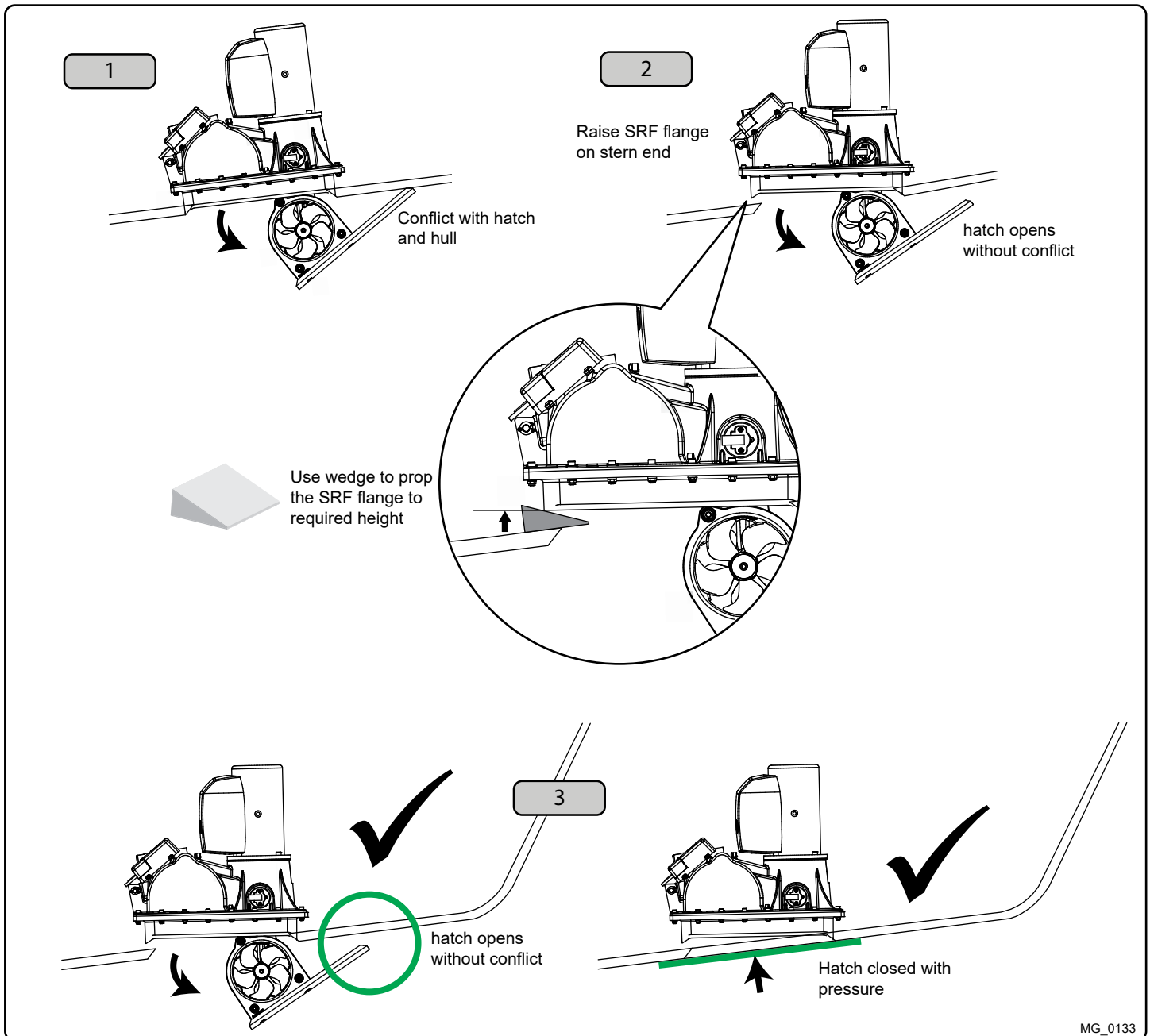

EN

Required Modifications After Pre-check

MC_0068

! Please refer to the graphic for special considerations relating to your model !

To increase the space between the hatch and the hull the entire SRF flange and motor must be raised at the stern end.

1. With the hatch in the open position raise the stern end of the SRF flange and motor until the appropriate clearance is achieved. **(NB: continue to raise the stern height until this is obtained.)**
2. Use a wedge to keep the thruster SRF flange and motor stable.
3. Open and close the hatch multiple times to ensure:
 - Clearance from the hull and hatch while open
 - Hatch closes flush with the hull and extra force is still transferred to the hull and hatch surface contact edges.
4. Record the height and kept the wedges in place for future moulding of the SRF flange.

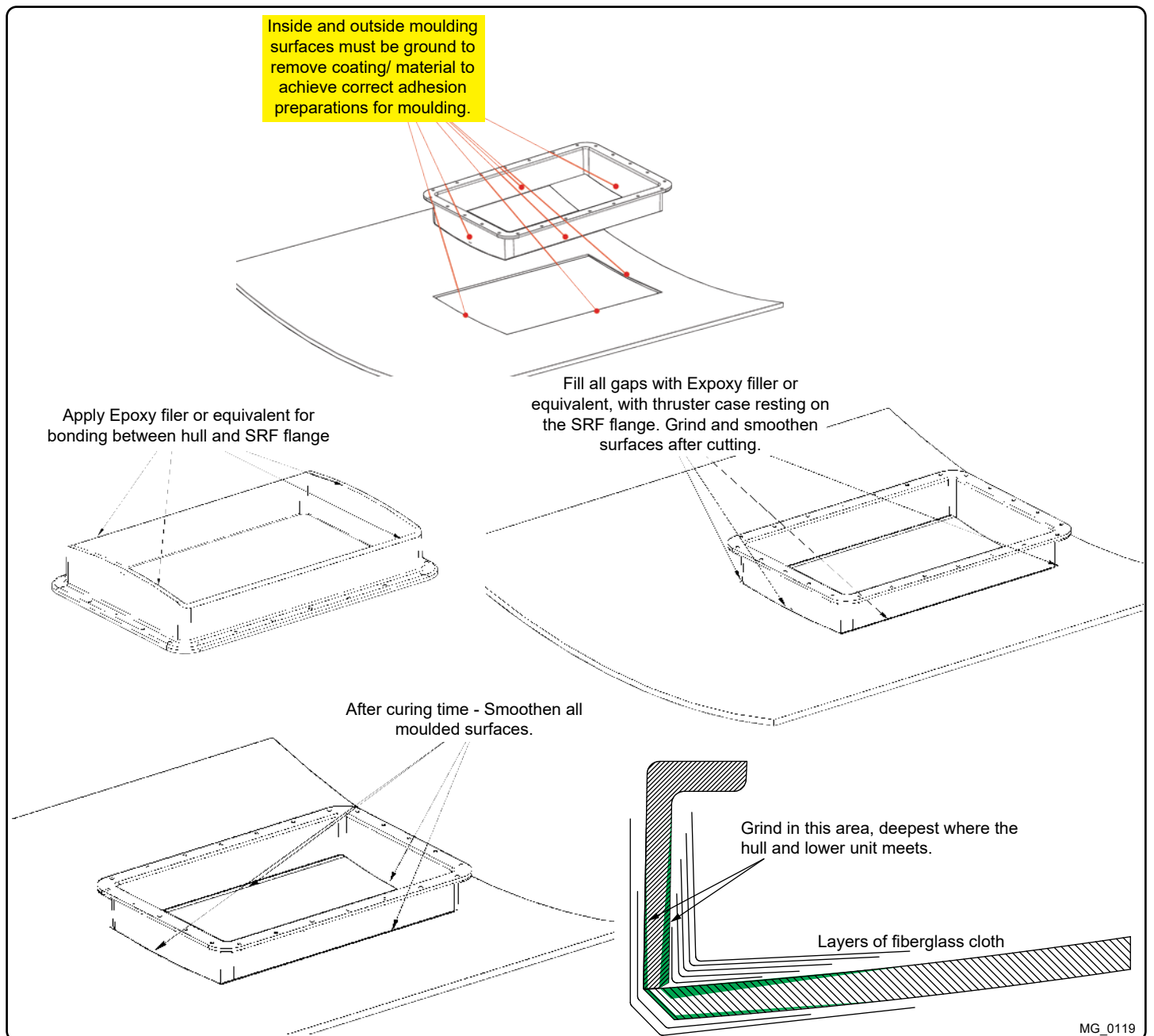

MG_0119

EN

SRF Flange Installation

MC_0068

! Please refer to the graphic for special considerations relating to your model !

1. Surfaces to be moulded/ bonded must be ground to remove coating and material for correct adhesion preparations to moulding in the SRF flange to hull.
2. Apply Epoxy filler or equivalent on bottom edges of SRF flange or on the hull for bonding between connection surfaces. Ensure the filler is compatible with hull materials.
3. Place the SRF flange into position ensuring the correct orientation. Fill gaps between SRF and hull with Epoxy filler or equivalent. Grind and smooth the surfaces after curing time.
4. Apply layers of fibre glass and ensure that resin is compatible with hull materials.
5. After curing time, smooth all moulded surfaces and apply coating. Apply putty before coating if necessary.

After moulding in SRF flange is completed, the upper thruster case is ready to be installed.

General Moulding process

Start the laminating with a strong attachment point in each corner between the hull and the outside of the lower unit. Use epoxy and fibreglass cutting or similar, which laminating material is the actual boat builders responsibility. Cover the upper part if grinding is necessary. After moulding material have cured, run the retract mechanism down, disassemble the hatch and remove the upper part from the unit.

Laminate the inside and outside of the lower unit part solid to the hull. Use appropriate fibreglass cloth (which laminating material is the actual boat builders responsibility). Before grinding of hull and unit lower part, precautions must be taken against grinding dust inside the boat. Grind deepest where the hull and lower unit part meets.

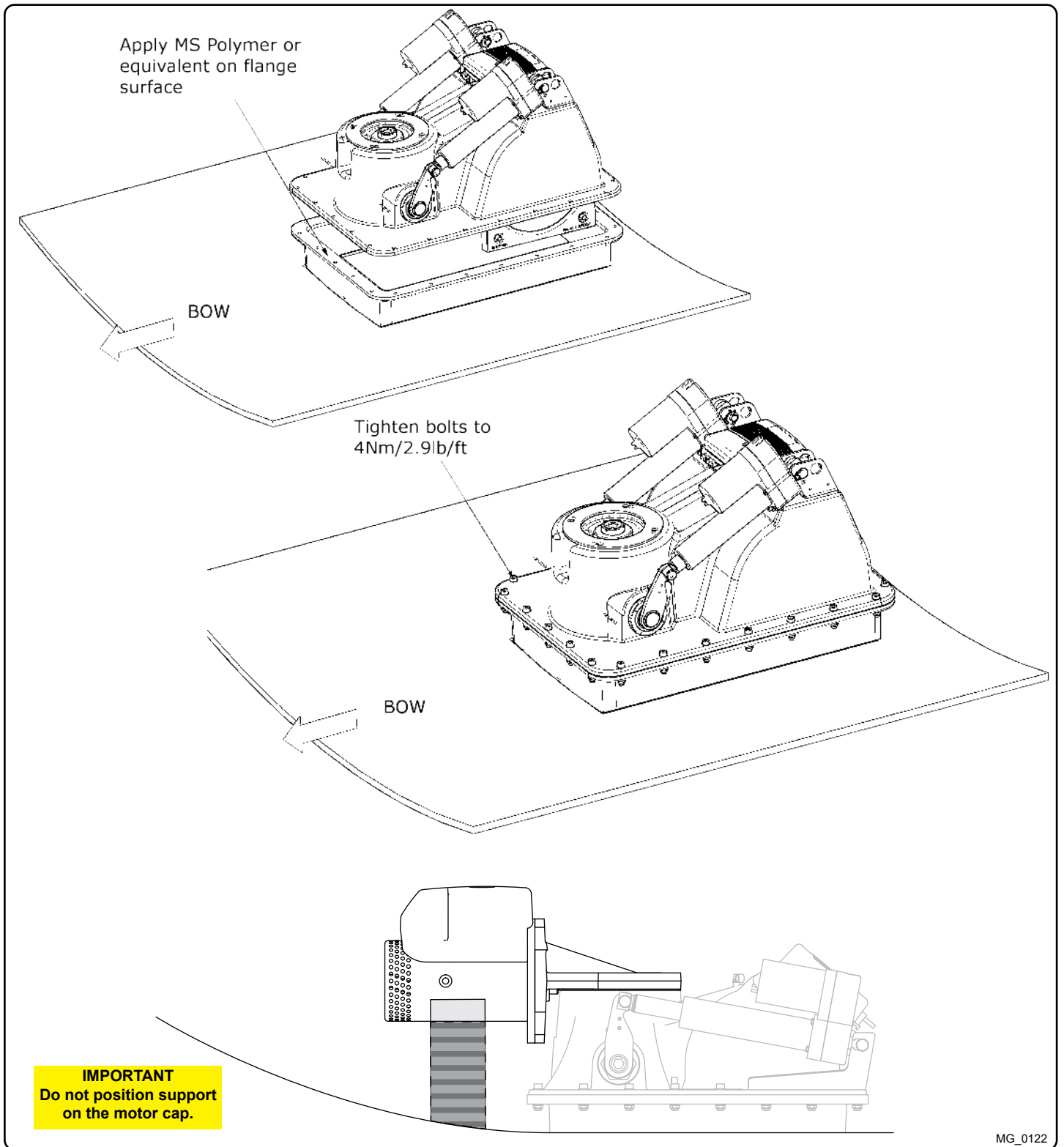

MG_0122

EN

Motor House Installation

MC_0068

! Please refer to the graphic for special considerations relating to your model !

1. Apply MS Polymer or equivalent on SRF flange top surface to seal and avoid water leakage. **(NB: Ensure that glue is compatible with SRF and thruster case materials.)**
2. Place the upper thruster Housing down on the SRF flange.
3. Insert and fasten bolts. Start with the 4 corner bolts followed by the remaining to required torque.

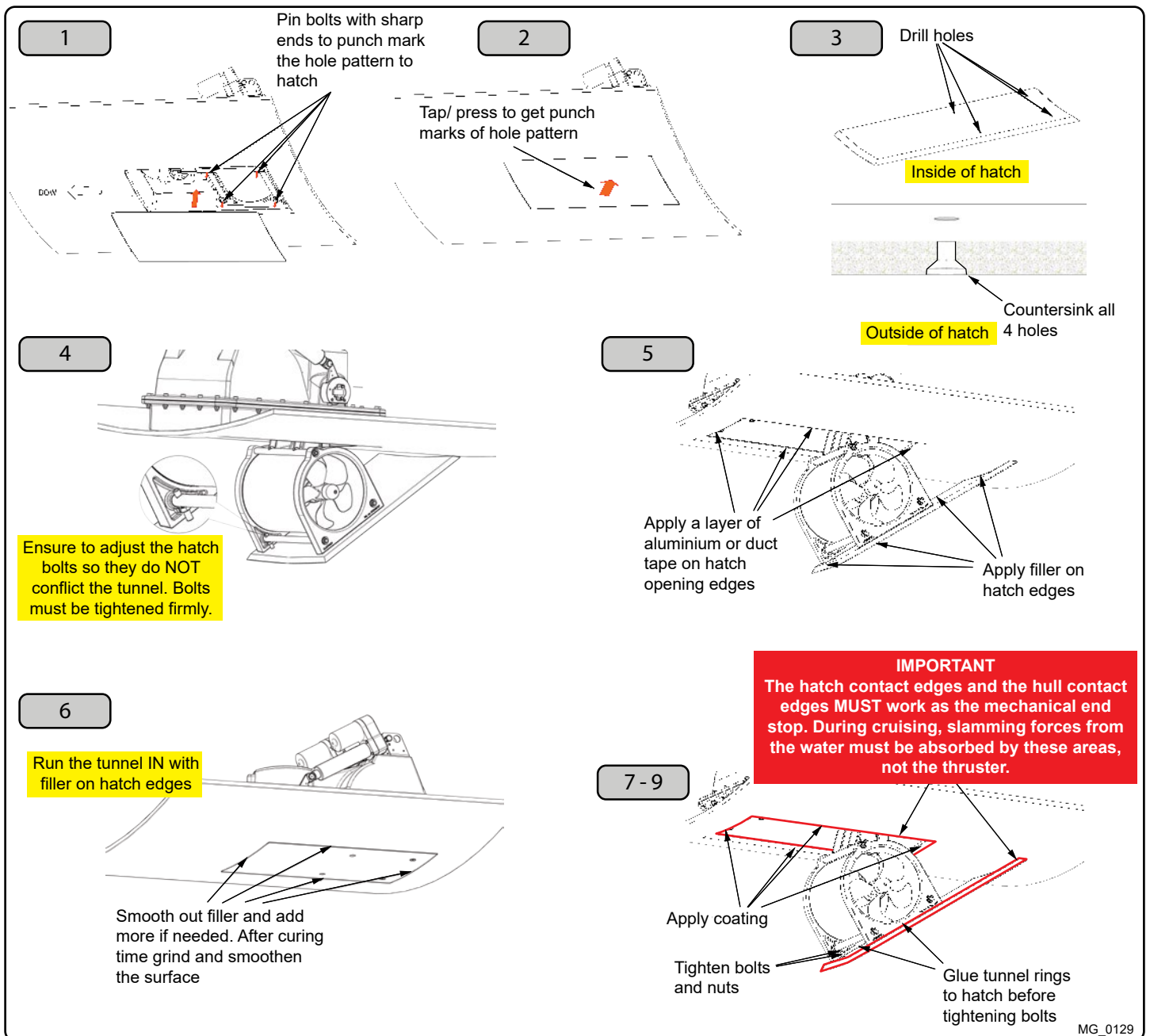

EN

Hatch Installation

MC_0068

! Please refer to the graphic for special considerations relating to your model !

1. Fit custom made pin bolts to the tunnel rings. The ends of the bolts must be sharp to create marks in the hatch. The pin bolts must be in correct height so the hatch will fit in its inner position.
2. Place hatch in its inner position, then press or tap with a hammer to create punch marks inside of the hatch.
3. Drill 4 marked holes and countersink the outer hull side. **(NB: drill holes 90 to the hatch surface.)**
4. Temporary fit the hatch to the tunnel rings. Ensure the bolts do NOT conflict with the propeller tunnel. **(NB: Bolts can be cut, depending on hull thickness.)**
5. Fill the gap between hatch and hull edges.
6. Apply a layer of aluminium or duct tape on hatch opening edges on the hull. Apply Epoxy filler or equivalent to hatch edges to create a perfect seal.
7. Operate the thruster to "IN" position. Smooth out the filler and add more if needed. After curing time, grind and smooth the surface.
8. Unscrew and remove hatch to smooth off excessive material before coating the hatch.
9. Apply filler on to tunnel rings contact surface, so the hatch will be secured properly. Now re-install hatch in its correct position. Tighten bolts so hatch will fit properly.
10. Apply coating inside and outside of hatch opening on hull.

Install the relevant motor and other electronics according to electrical instructions in the manual

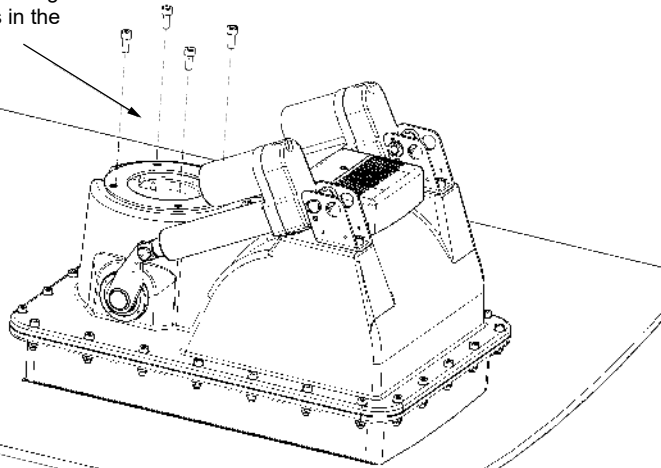

Bolt tightening force (4x)
33 Nm (24 lb/ft)

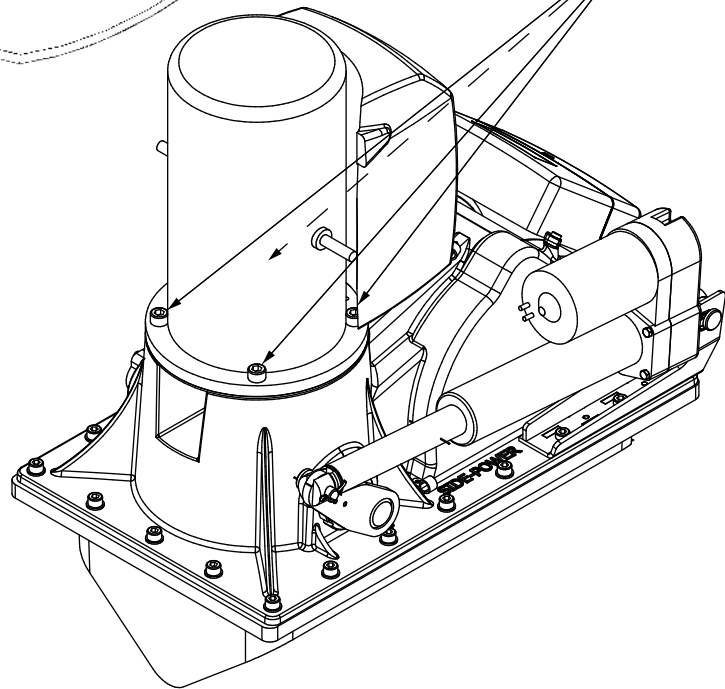

MG_0107

EN

Motor to House Installation

MC_0068

! Please refer to the graphic for special considerations relating to your model !

1. Install the motor onto the motor bracket ensuring both the couplings and the drive shafts have locked together. The motor must be installed with the solenoid facing the control box. **(NB: depending on your coupling you may need to wiggle the motor into place. Ensure the connection couplings are engaging correctly. Ensure the motor cable terminals are accessible for electrical installation later.)**
2. Fasten the bolts holding the motor to the motor bracket with the above torque.
3. Check the drive shafts engage by rotating the propeller. It is required the propeller can rotate via hand power. **(NB: Rotating the propellers can be hard because of the gear reduction and the motor.)**
4. Apply the gear leg and propeller with anti-fouling designed for propellers. Do not apply to the propeller drive shaft, the anodes or the end of the gear leg facing the propellers.

(NB: The motor must be covered to avoid dust from fabrication/ maintenance operation entering the motor or the solenoids. After fabrication maintenance operations have ceased the cover must be removed before operating the thruster.)

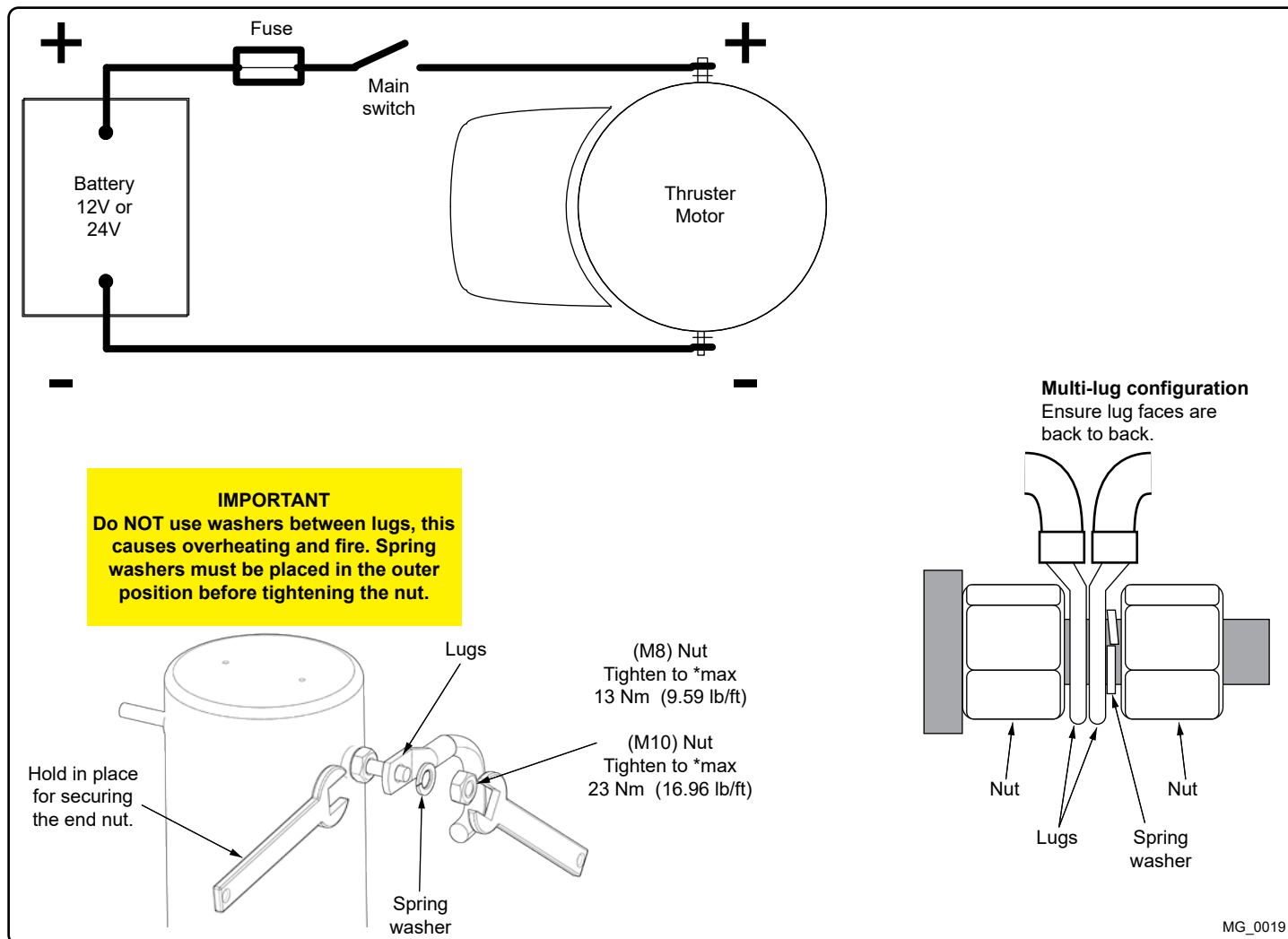

EN

Thruster Electrical Installation

MC_0035

! Please refer to the graphic for special considerations relating to your model !

1. Information of electrical table. *see next page*
 - All power cable lengths represent the total length of the combined (+) and (-) cables.
 - Battery capacity is stated as minimum cold crank capacity, (CCA).
 - Use slow blow rated fuses to hold stated Amp-Draw for min. 5 minutes.
 - Consider the AMP hours (Ah) for your specific duty cycle.
2. Use appropriate sized cables and batteries with high cranking capacity to feed the thruster. The actual voltage at the motor while running the thruster decides the motors output RPM and thrust. Use larger cables and stronger batteries for better results.
 - See electrical specifications for advised minimum cables and batteries (CCA).
3. Connect the battery supply to the control unit (PPC).
 - Install a main manual/ automatic switch from the positive lead terminal on the battery PPC unit). The main switch must be accessible to turn off the thruster independently from the rest of the electrical operation of the vessel when not on-board or in emergencies. **(NB: It is advised to install a fuse on the positive cable for protection against short-circuiting of the main cables. The fuse should ensure no voltage decrease, slow-blow and sized to take the amperage draw for at least 5 minutes.)**
 - A circuit breaker can be used instead of the fuse and main power switch If the functionality is the same.

(NB: For Ignition Protected installations remember to use ignition protected fuses and switches if fitted in areas that require this feature. Ensure to follow your national regulations)

5. Cable lugs must have adequate electrical and mechanical isolation and fitted with cable lug covers.
6. Fasten cables to the required torque.

WARNING

Check the following with the main switch is set to off :
 After all electrical connections have been completed check with an ohm meter that there is no electrical connection between
 1. electro-motor flange and the positive terminal on the motor
 2. electro-motor flange and the battery negative terminal on the motor

If unsure contact skilled personnel.



Electrical Specifications

MC_004

*Valid for DC motors

Model Size	System Voltage	Nominal current draw	Min. battery CCA	Rec. fuse	<7m total + & -		7-14m total + & -		15-21m total + & -		22-28m total + & -		28-35m total + & -		36-45m total + & -	
					Min.	Rec.	Min.	Rec.	Min.	Rec.	Min.	Rec.	Min.	Rec.	Min.	Rec.
*20/110S	12 V	150 A	DIN: 200 SAE: 380 EN: 330	ANL 150	25	35	35	50	50	70	70	95	95	95	120	2 x 70
					3	2	2	1/0	1/0	2/0	2/0	3/0	3/0	2 x 4/0	2 x 2/0	
*25/110S	12 V	200 A	DIN: 200 SAE: 380 EN: 330	ANL 150	25	35	50	50	70	70	95	95	120	120	2 x 70	2 x 70
					3	2	1/0	1/0	2/0	2/0	3/0	3/0	4/0	2 x 2/0	2 x 2/0	
*30/125S *30/140	12 V	245 A	DIN: 200 SAE: 380 EN: 330	ANL 150	35	50	50	70	70	95	95	120	120	2 x 70	2 x 70	2 x 95
					2	1/0	1/0	2/0	2/0	3/0	3/0	4/0	2 x 2/0	2 x 2/0	2 x 3/0	
*40/125S *40/140	12 V	315 A	DIN: 300 SAE: 570 EN: 520	ANL 250	35	50	70	95	95	120	120	2 x 70	2 x 70	2 x 95	2 x 120	2 x 120
					2	1/0	2/0	3/0	3/0	4/0	4/0	2 x 3/0	2 x 3/0	2 x 4/0	2 x 4/0	
*50/140S	12 V	370 A	DIN: 350 SAE: 665 EN: 600	ANL 325	50	70	70	95	120	2 x 70	2 x 70	2 x 95	2 x 95	2 x 120	2 x 120	2 x 120
					1/0	1/0	2/0	3/0	4/0	2 x 2/0	2 x 2/0	2 x 3/0	2 x 3/0	2 x 4/0	2 x 4/0	
*60/185S *60/140	24 V	170 A	DIN: 175 SAE: 332 EN: 280	ANL 150	25	25	25	35	35	50	50	50	70	70	70	70
					3	3	3	2	2	1/0	1/0	2/0	2/0	2/0	2/0	
*60/185S *60/140	12 V	370 A	DIN: 350 SAE: 665 EN: 600	ANL 325	50	50	70	95	120	2 x 70	2 x 70	2 x 95	2 x 95	2 x 120	2 x 120	2 x 120
					1/0	1/0	2/0	3/0	4/0	2 x 2/0	2 x 2/0	2 x 3/0	2 x 3/0	2 x 4/0	2 x 4/0	
*80/185T	24 V	280 A	DIN: 300 SAE: 570 EN: 520	ANL 250	35	35	35	50	50	70	70	95	95	120	120	2 x 95
					2	2	2	1/0	1/0	2/0	2/0	3/0	3/0	4/0	4/0	2 x 3/0
*100/185T	12 V	740 A	DIN: 750 SAE: 1425 EN: 1320	ANL 500	95	95	2 x 70	2 x 95	2 x 95	2 x 120	2 x 120	2 x 120	2 x 120	2 x 120	NA	NA
					3/0	3/0	2 x 2/0	2 x 3/0	2 x 3/0	2 x 4/0	2 x 4/0	2 x 4/0	2 x 4/0	2 x 4/0	2 x 4/0	
*120/215T	24 V	420 A	DIN: 450 SAE: 855 EN: 760	ANL 325	70	70	70	70	70	70	95	95	120	120	2 x 70	2 x 95
					2/0	2/0	2/0	2/0	2/0	2/0	3/0	3/0	4/0	4/0	2 x 2/0	2 x 3/0
*130/250T	12 V	800 A	DIN: 750 SAE: 1425 EN: 1320	ANL 500	95	95	2 x 70	2 x 95	2 x 95	2 x 120	2 x 120	2 x 120	2 x 120	2 x 120	NA	NA
					3/0	3/0	2 x 2/0	2 x 3/0	2 x 3/0	2 x 4/0	2 x 4/0	2 x 4/0	2 x 4/0	2 x 4/0	2 x 4/0	
*150/215T	24 V	610 A	DIN: 560 SAE: 1064 EN: 940	ANL 500	70	70	95	95	120	120	120	120	120	2 x 95	2 x 95	2 x 120
					2/0	2/0	3/0	3/0	4/0	4/0	4/0	4/0	2 x 3/0	2 x 3/0	2 x 4/0	2 x 4/0
*170/250	24 V	550 A	DIN: 560 SAE: 1064 EN: 940	ANL 400	70	70	70	95	95	120	120	120	120	2 x 95	2 x 95	2 x 120
					2/0	2/0	2/0	3/0	3/0	4/0	4/0	4/0	2 x 3/0	2 x 3/0	2 x 4/0	2 x 4/0
*210/250	24 V	500 A	DIN: 560 SAE: 1330 EN: 940	ANL 400-500	70	70	70	95	95	120	120	120	120	2 x 95	2 x 95	2 x 120
					2/0	2/0	2/0	3/0	3/0	4/0	4/0	4/0	2 x 3/0	2 x 3/0	2 x 4/0	2 x 4/0
*250/300	24 V	610-670 A	DIN: 700 SAE: 1330 EN: 1170	ANL 500	70	70	95	95	120	120	120	120	120	2 x 95	2 x 95	2 x 120
					2/0	2/0	3/0	3/0	4/0	4/0	4/0	4/0	2 x 3/0	2 x 3/0	2 x 4/0	2 x 4/0
*300/300	24*2 48V	400-450A (48V)	DIN: 400 SAE: 760 EN: 680	ANL 325	50	70	50	70	70	70	95	95	120	120	140	NA
					1/0	2/0	1/0	2/0	2/0	2/0	3/0	3/0	4/0	4/0	4/0	4/0

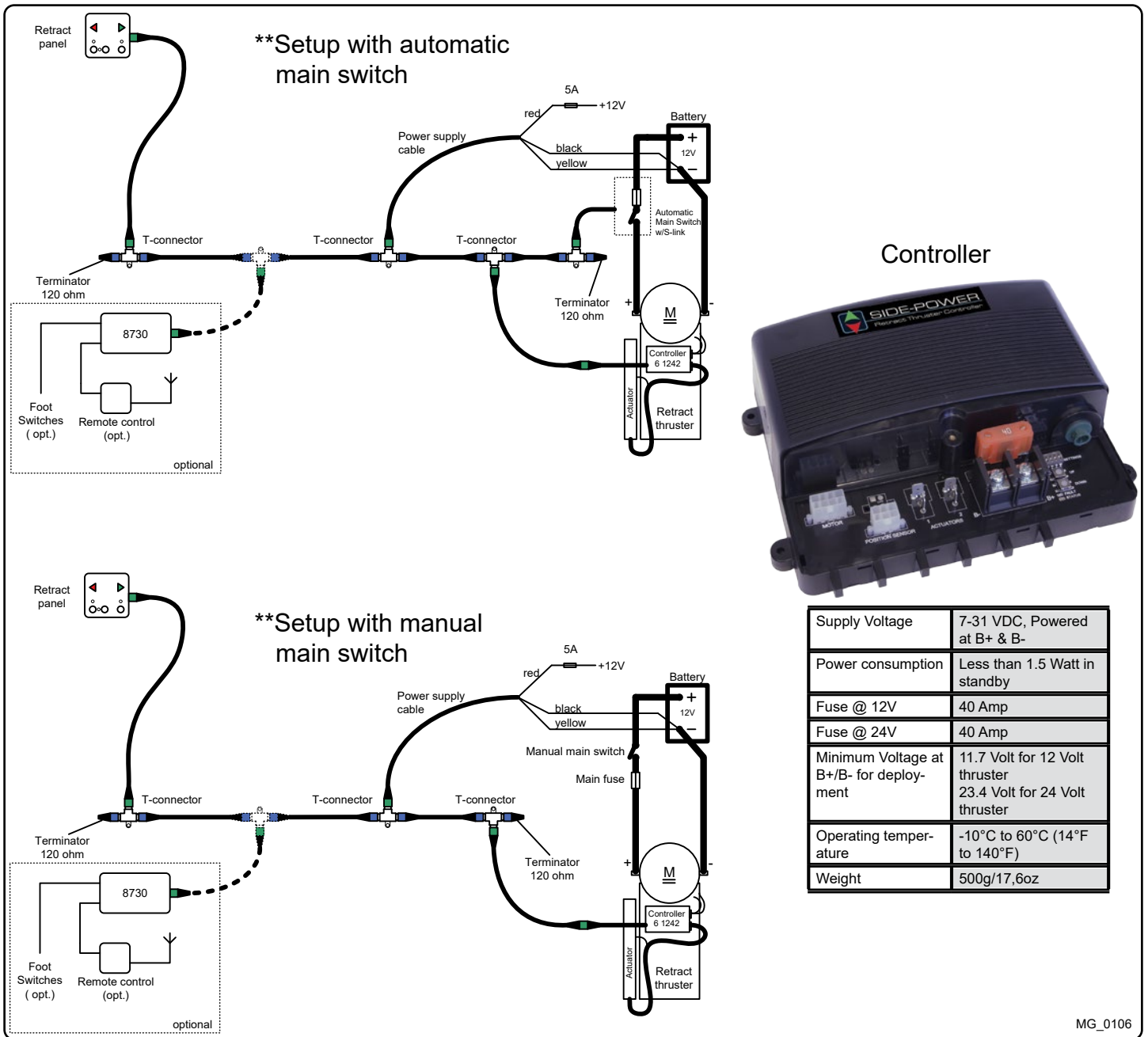

EN Control Panel Cable Installation MC_0041

! Please refer to the graphic for special considerations relating to your model !

- All Sidepower control panels can be used in any combination.
- All control panels can be installed using:
 - Y-connectors - for standard on/off
 - T-connectors - for S-link proportional power system.

(NB: If two or more control panels are operated at the same time in opposite directions, the electronic control box will stop the thruster until it receives a single signal or thrust in one direction.)

- Sidepower on/off equipment it is entirely "plug & play" and require no additional configuration setup.

See the Control panel manual for more information.

Example of the control wiring with S-link system for boats with one control position and one thruster.

Control Panel



You need:

- 2 x 6 1327 End terminators
- 3 x 6 1326 T-connectors
- 1 x 6 1328 Power spur
- 2 x 6 1320-xxM Backbone cables
- 2 x 6 1321-xxM Spur cables

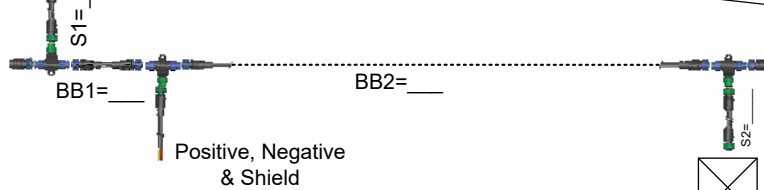

Thruster

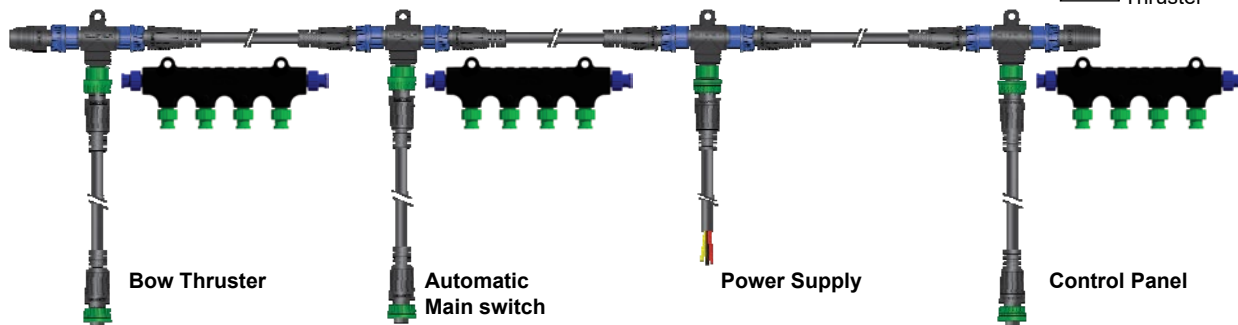

Bow Thruster

Automatic Main switch

Power Supply

Control Panel



BACKBONE Cable

Forms the main "loop" around the boat.



T- Connector

Must be one for each spur, including power cable



SPUR Cable

Must be used to connect all parts to the backbone cable (One for each component, no exceptions). Recommended to be as short as practically possible.



BACKBONE extender

Connects two BACKBONE cables to extend length.



POWER Cable

Must be one in each system, length 2.5m



END terminator

Must be one for each end of the BACKBONE "loop".



4-Port T Connector

The 4-port T-connector allows multiple spur cables to be connected. *(NB: Comes with two sealing caps to protect.)*

MG_0159

EN

S-link Planning & Precautions

MC_0120

S-link is a "CAN" based control system with full intelligent communication between all units in the system.

Main advantages include:

- Round, compact and waterproof plugs with unique keying and colour coding to avoid faulty hookup.
- An unlimited number of commands or information transfer on a single cable.
- Proprietary Sleipner commands but built 100% on NMEA 2000 standard.

Routing the Backbone:

Keep routing backbone spur cables to a minimum. Avoid routing the S-link cables close to equipment that might cause interference to the S-link signals such as radio transmitter equipment, antennas or high voltage cables. The backbone MUST be terminated at each end with the 6 1327 End Terminator.

Spur cables:

Spur cables can be left not terminated *(NB: Routing can be prepared for future additional equipment)*. Make sure to protect open connectors from water and moisture to avoid corrosion in the connectors.

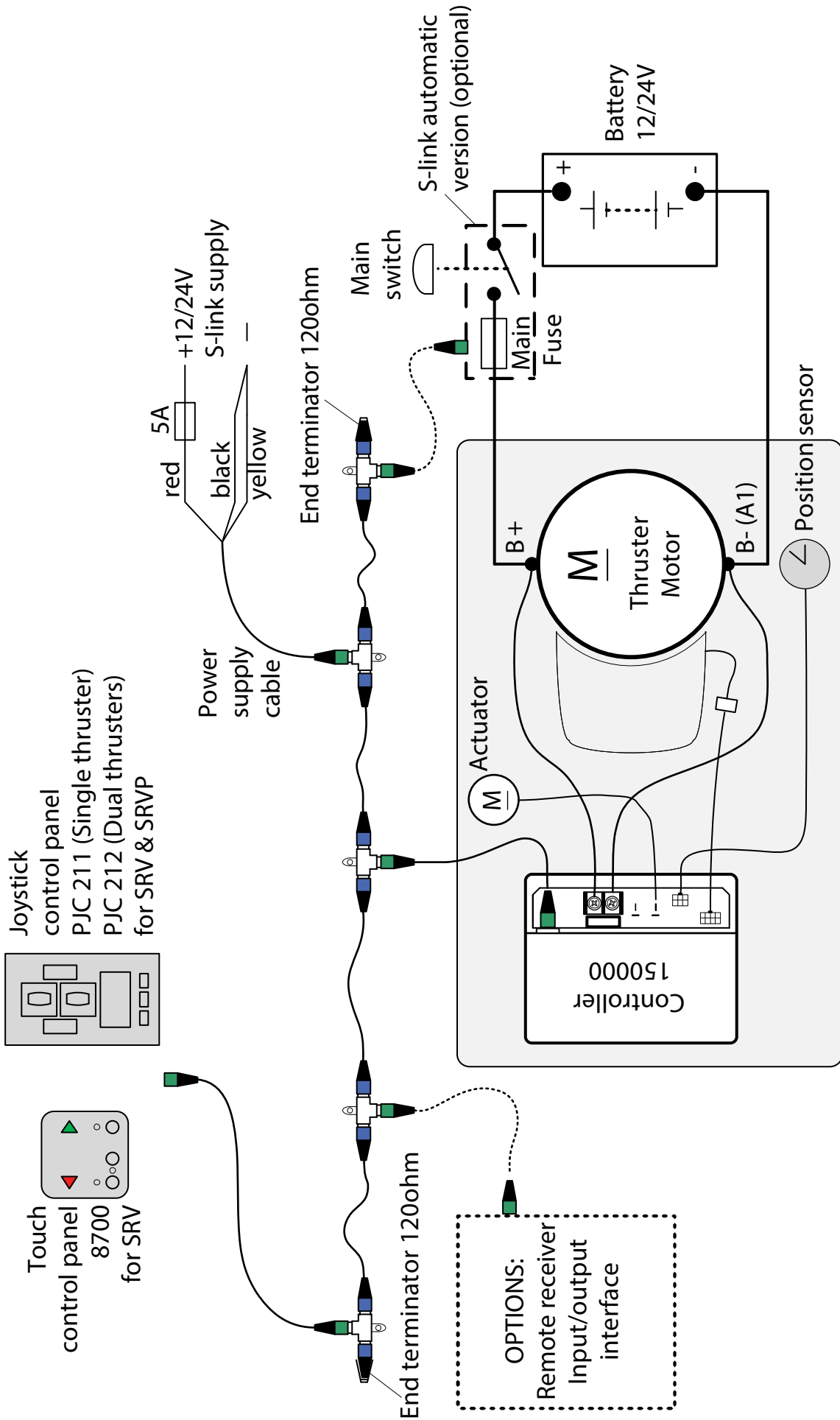

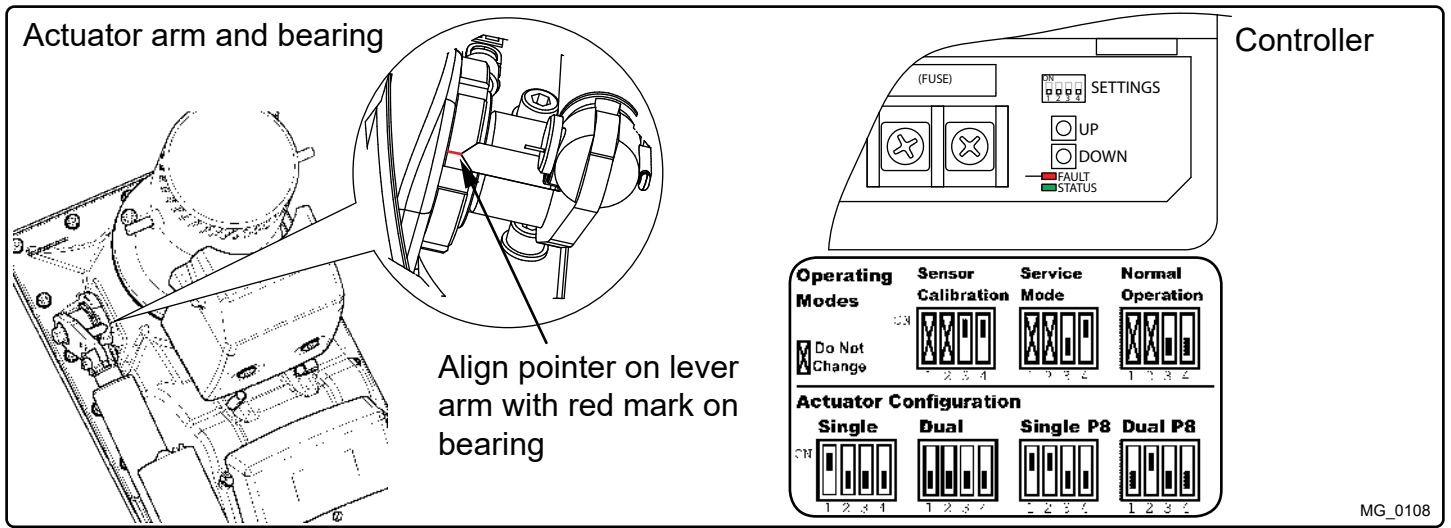

EN **Check drive shaft alignment** MC_0069

IMPORTANT
Before the thruster motor is operated, check the drive shaft alignment is completely straight when it reaches the end position form the control panel operation:

- 1) Connect power to thruster and S-link system.
- 2) Set DIP-switch on the controller to 0000.
- 3) Turn on the panel. (The drive shaft deploys.)
- 4) The actuator lever arm and the bearing are set to alignment marking
- 5) If marks align, turn panel off. Drive shaft retracts.
- 6) If the marks do not align, proceed to calibrate drive shaft.

EN **Calibrate drive shaft alignment** MC_0069

(NB: The drive shaft is correctly aligned when manufactured)

- 1) With dip-switches select 'Service Mode'.
- 2) Align the arrow on the actuator arm with the calibration mark, using the UP/DOWN buttons.
- 3) With dip-switches select 'Sensor Calibration Mode'.
- 4) Press and hold both UP and DOWN buttons until STATUS LED light up green.

(NB: If FAULT LED light-up red, then the calibration is out of position (wrong align mark).

- 5) With dip-switches select 'Operation Mode', thruster retracts.

EN **Actuator Configuration** MC_0069

Dip-switch number 1 & 2 configures the actuator(s).

No.1 set to OFF when the retract has two actuators.

No.1 set to ON when the retract only has one actuator.

No.2 set to OFF when the retract does not have P8 type actuator(s).

No.2 set to ON when the retract has the P8 type actuator(s).

If dip-switch no.2 is set to ON and the actuator gives a rattling noise when the door closes, then there probably is not P8 actuator(s) and dip-switch no.2 needs to be set to OFF.

The actuator is a P8 type:

- If the actuator has a plastic cap at the back where you can adjust the actuator manually.
- If it is marked with a sticker with P8
- If the manufacturer label says P8

EN **LED Indication** MC_0069

Continuous red light:

Motor over-temp, Controller over-temp, Controller no communication, Motor relay failure, Low battery voltage, Position sensor failure, No power to actuators, Retractable unit failure, Temp sensor open circuit.

Flashing red light:

Red light fast blinking: Dip-switch in an invalid position.

Red light short flash every 2 seconds: Shaft not calibrated, or shaft calibrated out of range.

Continuous green light:

Normal mode, Service mode (actuators operated by UP/DOWN buttons).

Re-calibrated "down"-position.

Flashing green light:

No S-Link communication.

CONTROL PANEL TEMPLATES

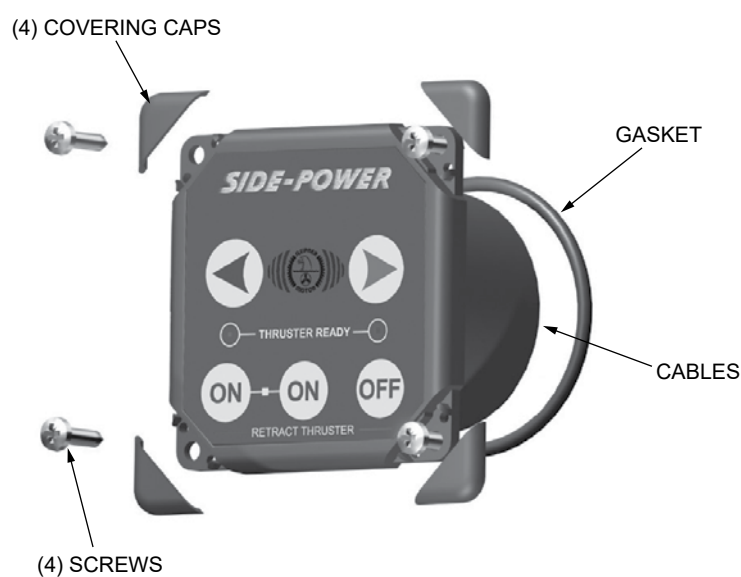
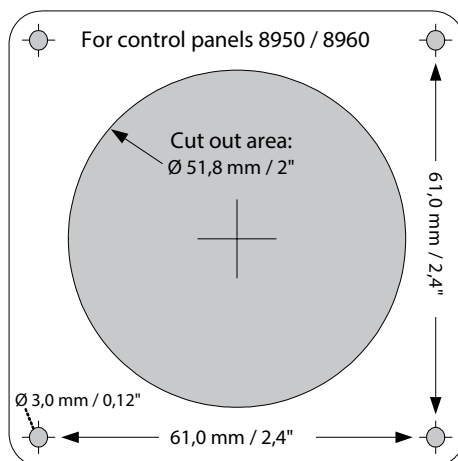

MG_0105

EN

Control Panel Installation

MC_0042

! Please refer to the graphic for special considerations relating to your model !

Find a suitable location for the control panel where it does not obstruct or is obstructed by other devices. Install the control panel on a flat surface where it is easy to use.

1. Use the supplied cut-out template to mark the area to remove on your control dash.
2. Cut out the area per template for the control panel. **(NB: If the front surface around your cut out is jagged or chipped, use a sealant to assist the gasket.)**
3. Place the gasket to the back face of the panel
4. Plug cables into the connectors at the rear of the control panel.
5. Insert the control panel in place and fasten screws.
6. Insert the control panels covering caps.

- The bolts holding the gear house and motor bracket together are tightened correctly.
- The bolts holding the motor to its bracket are tightened correctly.
- All electrical connections are clean, dry and tight, and the correct cable, fuse and main switch size.
- Check that there is no electrical connection between the electro motor body and positive terminal on the motor, and between the electro motor body and the negative (A1) terminal on the motor with an ohm meter.
- Anti-fouling has been applied to the gear house and propeller but NOT anodes, sealing/ rubber fittings or propeller shafts.
- Propeller is fastened correctly to the shaft.
- Propeller turns freely in tunnel.
- The anode and/ or holding screw is tightened well with thread glue.
- Check the boat for potential water leakage around installation areas.
- Correct drive direction as per control panel.
- User Manual is supplied to the owner.

The thruster has been installed as per the instructions in this manual and all points in checklist above have been controlled.

Signed:

Date:

Thruster type:

Serial number:.....

Date of delivery:.....

Correct drive direction as per control panel:

The compartment for the thruster has been isolated from general bilge water and has no obvious or suspected risks for flooding:

.....
.....
.....

Other comments by installer:

.....
.....

For the most up to date documentation, we advise you to visit our website www.side-power.com for the spare parts list.

For additional supporting documentation, we advise you to visit our website www.side-power.com for the spare parts list.

1. The equipment manufactured by Sleipner Motor AS (The "Warrantor") is warranted to be free from defects in workmanship and materials under normal use and service.
2. This Warranty is in effect for of two years (Leisure Use) or one year (Commercial use) from the date of purchase by the user. Proof of purchase must be included, to establish that it is inside the warranty period.
3. This Warranty is transferable and covers the product for the specified time period.
4. In case any part of the equipment proves to be defective, other than those parts excluded in paragraph 5 below, the owner should do the following:
 - (a) Prepare a detailed written statement of the nature and circumstances of the defect, to the best of the Owner's knowledge, including the date of purchase, the place of purchase, the name and address of the installer, and the Purchaser's name, address and telephone number;
 - (b) The Owner should return the defective part or unit along with the statement referenced in the preceding paragraph to the warrantor, Sleipner Motor AS or an authorized Service Centre, postage/shipping prepaid and at the expense of the Purchaser;
 - (c) If upon the Warrantor's or Authorized Service Centre's examination, the defect is determined to result from defective material or workmanship, the equipment will be repaired or replaced at the Warrantor's option without charge, and returned to the Purchaser at the Warrantor's expense;
 - (d) no refund of the purchase price will be granted to the Purchaser, unless the Warrantor is unable to remedy the defect after having a reasonable number of opportunities to do so. Prior to refund of the purchase price, Purchaser must submit a statement in writing from a professional boating equipment supplier that the installation instructions of the Installation and Operation Manual have been complied with and that the defect remains;
 - (e) warranty service shall be performed only by the Warrantor, or an authorized Service Centre, and any attempt to remedy the defect by anyone else shall render this warranty void.
5. There shall be no warranty for defects or damages caused by faulty installation or hook-up, abuse or misuse of the equipment including exposure to excessive heat, salt or fresh water spray, or water immersion except for equipment specifically designed as waterproof.
6. No other express warranty is hereby given and there are no warranties which extend beyond those described in section 4 above. This Warranty is expressly in lieu of any other expressed or implied warranties, including any implied warranty of merchantability, fitness for the ordinary purposes for which such goods are used, or fitness for a particular purpose, and any other obligations on the part of the Warrantor or its employees and representatives.
7. There shall be no responsibility or liability whatsoever on the part of the Warrantor or its employees and representatives for injury to any person or persons, or damage to property, loss of income or profit, or any other consequential or resulting damage or cost which may be claimed to have been incurred through the use or sale of the equipment, including any possible failure or malfunction of the equipment, or part thereof.
8. The Warrantor assumes no liability for incidental or consequential damages of any kind including damages arising from collision with other vessels or objects.
9. This warranty gives you specific legal rights, and you may also have other rights which vary from country to country.

Worldwide sales and service



www.side-power.com



SLEIPNER MOTOR * AS P.O. Box 519 * N-1612 Fredrikstad * Norway

The information given in the document was correct at the time it was published. However, Sleipner Motor AS can not accept liability for any inaccuracies or omissions it may contain. Continuous product improvement may change the product specifications without notice. Therefore, Sleipner Motor AS can not accept liability for any possible differences between product and document.

MC_0030